



SimLEARNSM
Excellence in Veterans' Healthcare

Simulation Update:

A Review of Simulation-Based Strategies for Healthcare, Education and Training

June 2010

EDITORS

Rosalyn P. Scott, MD, MSHA

*Associate Chief of Staff for Medical Education and Director of Simulation
Dayton VAMC*

*Professor of Surgery
Boonshoft School of Medicine*

*Professor of Biomedical, Industrial and Human Factors Engineering
College of Engineering and Computer Science
Wright State University
Dayton, Ohio*

Louise R. Van Diepen, MS, CGP

*Deputy Chief Learning Officer
Employee Education System
Veterans Health Administration
Washington, DC*

Ronald J. Markert, Ph.D.

*Professor and Vice Chair for Research
Department of Internal Medicine*

Professor of Surgery

Professor of Orthopaedic Surgery, Sports Medicine & Rehabilitation

*Boonshoft School of Medicine
Wright State University
Dayton, Ohio*

ACKNOWLEDGEMENT

The Editors wish to acknowledge the contributing authors and their staff who worked tirelessly to create this monograph. Their efforts are appreciated by the SimLEARN community and by all who are interested in increasing their understanding of simulation-based strategies in healthcare education and research.

Table of Contents

FOREWORD	1
MANNEQUIN-BASED SIMULATION IN HEALTHCARE.....	5
WHAT IS MANNEQUIN-BASED SIMULATION?	5
FIDELITY – A PROPERTY OF SIMULATIONS, NOT OF SIMULATORS.....	7
AREAS OF APPLICATION OF MANNEQUIN-BASED SIMULATION.....	9
<i>Purpose</i>	10
OTHER DIMENSIONS OF SIMULATION APPLICATIONS.....	10
<i>Unit of Participation</i>	11
<i>Venue of Simulation - Relationship Between In-Situ Simulation and Dedicated Simulation Center</i>	11
<i>Modes of Teaching with Mannequin-Based Simulations</i>	12
DEBRIEFING	14
SIMULATION FOR TECHNICAL SKILL VS. NON-TECHNICAL SKILLS	15
TEAM TRAINING – RELATIONSHIP BETWEEN SINGLE DISCIPLINE AND COMBINED TEAM TRAINING PARADIGMS ...	16
SUMMARY AND CONCLUSIONS	17
REFERENCES	18
ABOUT THE AUTHORS	19
TASK TRAINERS AND HAPTICS	21
INTRODUCTION TO TASK SIMULATION AND AVAILABLE TECHNOLOGY	21
<i>Simulation Theory</i>	22
<i>Types of Available Task Simulators</i>	23
<i>Haptics</i>	26
<i>High vs. Low Fidelity</i>	26
APPLICATION TO CLINICAL PRACTICE.....	27
<i>Curriculum Design</i>	27
<i>Integration into Training and Practice</i>	29
EVALUATION AND OUTCOME MEASUREMENT	31
<i>Assessment</i>	31
<i>Validity and Reliability</i>	32
FUTURE PRACTICE.....	33
COST	34
REFERENCES	34
ABOUT THE AUTHORS.....	38
STANDARDIZED PATIENTS.....	40
TEACHING WITH STANDARDIZED PATIENTS.....	41
TESTING WITH STANDARDIZED PATIENTS	44
RESEARCH WITH SPS	47

OTHER CREATIVE USES OF SPs.....	48
SUMMARY.....	49
REFERENCES	50
AUTHORS NOTES.....	53
ABOUT THE AUTHORS.....	54

DESIGNING, DEVELOPING AND IMPLEMENTING BRANCHED-NARRATIVE VIRTUAL PATIENTS FOR MEDICAL EDUCATION, TRAINING AND ASSESSMENT: A GUIDE FOR AUTHORS OF VIRTUAL PATIENTS..... 55

INTRODUCTION	55
<i>Key educational characteristics of virtual patients</i>	56
<i>Anatomy of a branched-narrative virtual patient</i>	57
CREATING A VIRTUAL PATIENT SIMULATION.....	57
PHASE I – PREPARATION	58
<i>List learning outcomes</i>	58
<i>Define the audience</i>	58
<i>Assess the environmental factors</i>	59
<i>Perform due diligence</i>	60
PHASE II – DESIGN AND DEVELOPMENT	61
<i>Select a pedagogical model</i>	61
<i>Nine steps for efficient and effective VP design and development</i>	62
PHASE III – IMPLEMENTATION.....	68
<i>Establish motivation</i>	68
<i>Distributing VP cases</i>	69
<i>Case meta-data</i>	69
<i>Ongoing evaluation</i>	70
<i>Maintenance and growth</i>	70
<i>Reporting</i>	71
EXAMPLES OF TYPICAL VP IMPLEMENTATIONS.....	71
CONCLUSIONS.....	72
REFERENCES	73
ABOUT THE AUTHOR.....	74

VIRTUAL ENVIRONMENTS..... 76

INTRODUCTION	76
THE TECHNOLOGY.....	77
<i>Computer</i>	77
<i>Visual Displays</i>	77
<i>Tracking Systems</i>	78
<i>Input Devices</i>	79
<i>Sound</i>	79
<i>Haptics</i>	80
<i>Software</i>	80
<i>Considerations, Advantages and Disadvantages</i>	80
APPLICATIONS TO CLINICAL PRACTICE	81

<i>3D Models/Visualizations</i>	82
<i>Mental Health</i>	83
<i>Surgical Training</i>	85
<i>Rehabilitation</i>	86
<i>VE Social Networks</i>	88
<i>Other Applications</i>	90
EVALUATIONS/OUTCOME MEASUREMENTS.....	90
FUTURE PRACTICE.....	91
COST.....	92
CONCLUSION	92
ACKNOWLEDGEMENTS.....	93
REFERENCES	93
ABOUT THE AUTHORS.....	96
PROCESS MODELING USING SIMULATION.....	98
INTRODUCTION	98
SIMULATION IN MODELING HEALTH CARE PROCESSES.....	100
<i>Capacity Planning</i>	100
<i>Patient Flow Analysis</i>	104
<i>Scheduling</i>	105
<i>Other Applications</i>	107
CASE STUDIES	108
<i>Case 1: Optimizing Length of Stay of Patients in the Emergency Department</i>	108
<i>Case 2: Emergency Preparedness Planning</i>	109
SIMULATION SOFTWARE AND ASSOCIATED COSTS	111
FUTURE OF SIMULATION IN PROCESS MODELING	112
REFERENCES	113
ABOUT THE AUTHORS.....	115

Foreword

Rosalyn P. Scott and Louise R. Van Diepen

In healthcare, simulation is becoming an essential component of education, training, assessment, and the maintenance of professional certification. Substantial advances in technology in the last two decades have resulted in new and remarkable ways of creating simulated environments that can enhance or substitute for experiences with living patients. Simulation strengthens confidence and promotes competence by providing a safe and supportive environment for mastering skills, practicing protocols, learning system-based practice, applying critical decision making, and developing communication and interpersonal skills. The potential for simulation to improve patient safety, reduce medical errors and deaths, and decrease health care costs is far from fully realized.

Throughout their curricula health profession schools have incorporated simulations that range from basic task trainers and standardized patients to high fidelity mannequins and virtual patients. Practicing professionals have been slower to adopt simulation methods for safety or quality initiatives and as a life-long learning strategy. Compared to other high-risk industries, healthcare has been slow to incorporate simulation into its training, assessment, and certification activities.

This hesitancy to adopt simulation is beginning to change. All candidates for the American Board of Surgery's Qualifying Examination must successfully complete a simulation-based Fundamentals of Laparoscopic Surgery course to sit for the examination. Further, the American Board of Medical Specialties is incorporating simulation training in its Maintenance of Certification requirements. For example, the American Board of Anesthesiology Maintenance of Certification in Anesthesiology (MOCA) program requires a candidate to complete a simulation course once during his/her ten-year MOCA cycle. Diplomates of the American Board of Internal Medicine can receive credits toward their Maintenance of Certification requirements by completing a medical simulation that provides hands-on opportunity to perform cases that mirror what a physician would typically face in daily practice.

It is critical that the Veterans Health Administration (VHA) develops a coordinated effort in simulation training, education, and research to maximize the benefits of simulation for its staff and Veterans. Such an enterprise can capitalize on VHA's extensive investment in simulation resources; develop system-wide policies, guidelines, documentation strategies, and protocols; and provide essential curricula and competency evaluation tools. Additionally, mechanisms should be established that allow VHA to assess the effectiveness of its simulation training initiatives and to share the findings from its simulation research and development.

Consequently, on July 17, 2009 the Acting Under Secretary for Health authorized the establishment of a national simulation training and education program for the Veterans Health Administration. Named SimLEARN (Simulation Learning, Education, and Research Network), the program's mission is to develop and maintain a national strategy for the deployment of simulation training and education across VHA. SimLEARN will ensure that VHA optimizes its resources and applies new training technologies toward the ultimate goal of improving the quality of health care for Veterans.

A deliberate five-step process has guided SimLEARN's initial development:

- determining the system-wide baseline for simulation activities (i.e., the “as is” state);
- identifying the best practices both within and external to VHA;
- defining the ideal (“to be”) state for VHA simulation and education;
- assessing gaps between the “as is” and the “to be” states; and,
- developing a strategic plan for progressing from the current state to the ideal state over a reasonable period of time.

VHA has completed the first step of that development process with the conclusion of its baseline “as is” study of the current state of VHA simulation training and education programs. This study included the November 2009 system-wide collection of data related to simulation training and education. These data were subsequently analyzed to 1) assess the “as is” state of simulation training and education across the system and 2) evaluate future simulation training and education needs. The final report of this

first-ever national evaluation of simulation was distributed to VHA leaders in January 2010. The report revealed the relative immature state of VHA simulation programs, thereby presenting VHA with a unique opportunity to chart a structured and systematic approach to its simulation education, training, and research program.

Our report presented here is a component of the second step of the planning process, the identification of best practices. Nationally recognized experts review best practices in various aspects of simulation – mannequin-based simulation, task trainers and haptics, standardized patients, virtual patients, virtual environments, and process modeling. Many of these simulation technologies are practiced widely in health professions education while others are only beginning to be appreciated by those who teach and evaluate healthcare personnel. These best practices document the current state of the art, establish benchmarks, and provide the foundation for describing the ideal state.

In their paper on mannequin-based simulation, Gaba and Feaster discuss the dimensions of simulation applications and the arenas in which mannequins have been deployed. They recognize that while there will never be Level 1A evidence, simulation is a sensible evolution from the traditional system of lecture and apprenticeship in healthcare education and training.

Task trainers are of particular value to procedural specialties. Time to competence tends to be reduced when novices engage in deliberate practice and have explicit permission to fail as they learn new procedures in a simulated environment. Wright and Pellegrini discuss in detail the types and advantages of specific task trainers.

Standardized patients can serve as valuable teaching colleagues in each phase of the learning cycle - experience, reflection, synthesis, re-experience. Yudkowsky and Blatt on behalf of the Association of Standardized Patient Educators describe the principles of teaching and assessing a variety of competencies using standardized patients.

Strategies based on virtual patients provide unique opportunities to learn clinical reasoning and can be widely distributed. McGee provides a step-by-step guide to the development of effective virtual patient scenarios.

Gallimore, Parikh, and colleagues present less commonly implemented simulation methodologies using virtual environments and process modeling. Both approaches are becoming increasingly important to healthcare training, education, and research.

These best practices, in addition to data collected during site visits to VHA and notable non-VHA sites, and evidence from the simulation literature, will help formulate a complete vision of VHA's ideal state. While this information is extremely useful in the strategic planning process, it should be equally useful to VHA educators in the field who are responsible for maintaining or implementing simulation education and training programs.

Mannequin-Based Simulation in Healthcare

David M. Gaba and Sandra J. Feaster

The field of interactive mannequin-based simulation in healthcare has more than 20 years of continuous history with antecedents going back 40 years. The scope of the undertakings in this field are very broad, and it would be impossible to specify literature on best practices in the absence of specific information on a number of different elements of any given simulation application. Eleven dimensions of simulation applications have been articulated previously.

A mannequin-based simulation application will include a combination of some of these 11 dimensions. We will discuss these dimensions and the issues and choices that present themselves when implementing a simulation curriculum using mannequin-based simulation.

What is Mannequin-Based Simulation?

Mannequin-based simulation encompasses the modalities of simulation that use a physical mannequin (typically of a whole body) to replicate the patient in clinical encounters. (The term “manikin” can also be used. The etymology of “mannequin” vs. “manikin” has been discussed in detail in the editorial “what’s in a name”.) Mannequin-based simulation is one approach to representing the patient rather than using actors, computer diagrams, animations, videos, or virtual reality. In general, mannequin-based simulation is also distinct from using part-task or procedural trainers that address only a specific body part and/or task (e.g., laparoscopic surgery; central venous cannulation, or a pelvic examination).

The scope for mannequin use is quite extensive, ranging from completely passive mannequins that represent a body form for practicing the transfer of a “patient” from point A to point B to very complex computer-controlled mannequins with physiologic models that breathe and have a heart rate, palpable pulses, and blood pressure. In addition, mannequins often include elements from other modalities of simulation. Thus, many mannequins include part-task components allowing specific invasive procedures (such as IV or central venous cannulation) within a more comprehensive

Figure 1. Eleven dimensions of simulation applications.

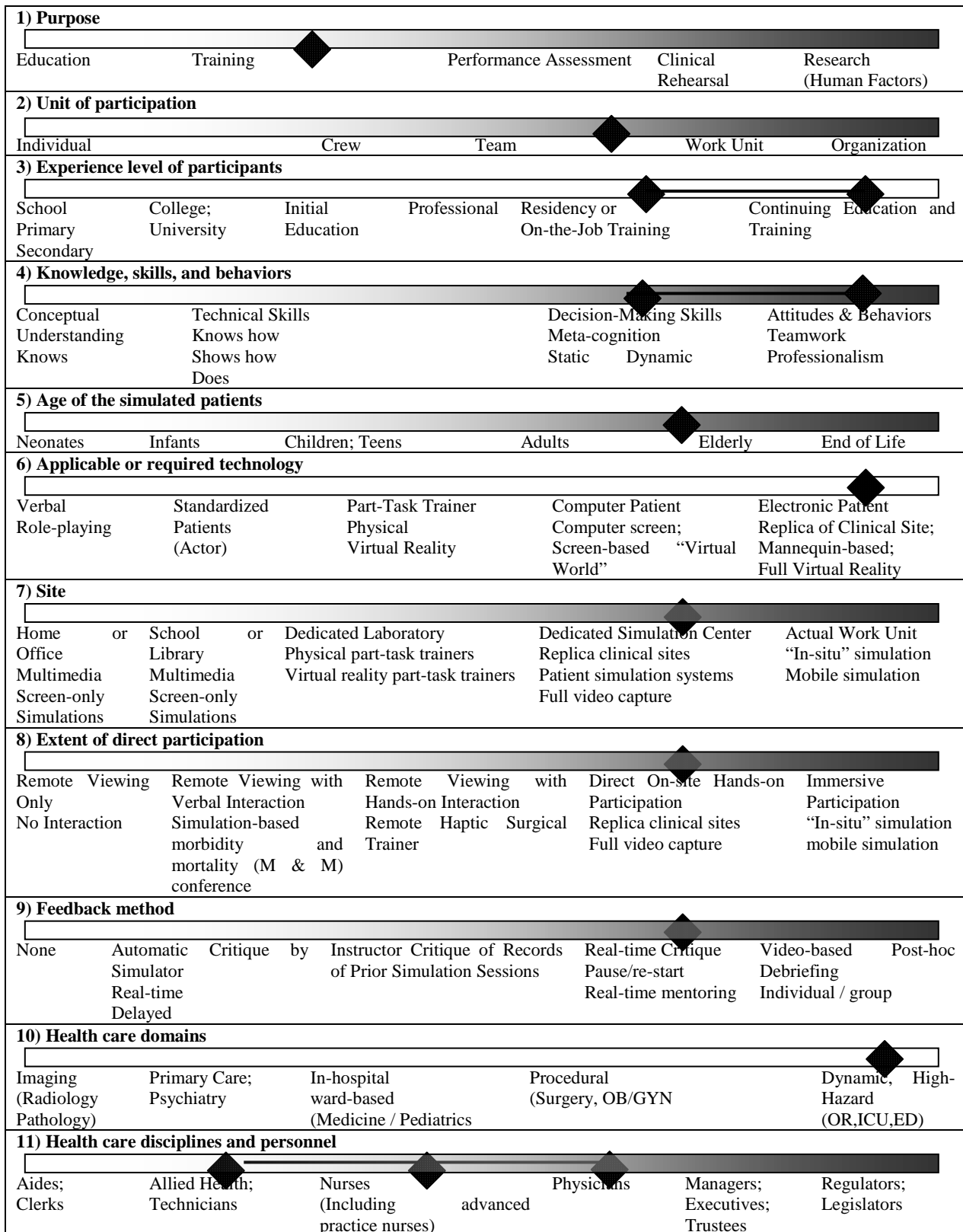

Application can be represented as a point or range on each dimension (shown as diamonds). The example illustrates a multidisciplinary, Crisis Resource Management, teamwork training exercise for ICU personnel.

patient representation. Similarly, many mannequin-based simulators have electronics in the patient's head that allow an instructor or actor to speak as the patient; thus providing a hybrid between the mannequin and the human standardized patient actor.

A mannequin-based simulation must be matched appropriately to the other aspects of the education application. In particular, the target population of learners or participants, the purpose of the simulation, and the site of the simulation will determine the minimum set of features needed. Simulation manufacturers have found that particular groups of customers do not always use all of a mannequin's features and that there is a trade-off between the cost of features and their utility for the educator in any field.

Fidelity – A Property of Simulations, Not of Simulators

There is often discussion of the “fidelity” of a simulator – intending to mean how close the patient representation is to reality. However, fidelity refers to the simulation – how the simulator is used in context to represent a patient care situation – rather than to the simulator device itself. The elements of realism and fidelity have been dissected in a series of papers and editorials.⁴⁻⁶

The term “features” or “feature set” is better for describing what a specific mannequin-based simulation device can or cannot do, as well the degree to which a given feature replicates the physical appearance or physiologic behavior of a human being. For example, a mannequin may or may not have fake eyes. The fake eyes may have pupils that can vary in diameter or which can restrict in response to bright lights. The eyelids may open and close on command, allowing blinking, or close when consciousness is lost. These are features of a simulator that may or may not contribute meaningfully to the fidelity of a simulation. Similarly, the data streams that can be presented electronically via a real or virtual physiologic

Figure 2. Instructors using OB part-task trainer to demonstrate delivering a baby.



monitor can also vary in number and flexibility of control. Again, these different features distinguish simulator devices, but may not distinguish the overall fidelity of specific simulation applications that use the devices.

It is not possible to delineate all the features of the different models of mannequin-based simulators that are on the market. Users must match the feature set they need for their chosen application(s) against those available in the different choices of devices, while assessing issues of cost, flexibility, and portability, to make reasonable decisions of what system to procure and use.

One major difference between simulation devices is the method and degree of autonomy of control of the vital signs and clinical features of the simulator. The most sophisticated strategy is to create complex mathematical models of the physiology of the human body in normal and abnormal clinical conditions as well as its response to drugs and other interventions. This advanced approach to technological simulators is used in the fields of aviation, nuclear power, and military science. The model-driven approach has two advantages: a) autonomy (in theory, if not in practice) and b) the ability to accurately, rapidly, and reproducibly change clinical conditions with modest intervention by the instructor or operator. However, it has proven challenging to make robust models of physiology that work seamlessly in dynamic situations.

The other approach is to rely on direct control by the operator of all the clinical data and features, sometimes augmented by software “scripts” to automate certain stereotyped responses in well-defined clinical situations. This operator-driven approach is simpler and flexible, provided that the operator or instructor can reproduce changes in vital signs and cues as appropriate to the treatments given by the clinicians.

In the end, the clinician “in the hot seat” often cannot tell the difference between a simulator that is driven by sophisticated models versus those that are controlled by simpler means. Thus, the choice between more and less sophisticated models requires the buyer to balance many different factors. In general, it has proven possible to conduct a wide variety of simulation applications, including very complex ones, with many different models of simulators using different approaches of control.

Areas Of Application Of Mannequin-Based Simulation

Since most mannequin-based simulators are intended to be general purpose interactive representations of patients, they are usable in a wide variety of simulation applications with many different target populations in many different domains and disciplines of healthcare. The distinguishing features of mannequins vs. actors are

Figure 3. Setting up the mannequin for a simulation.



that a) mannequins provide a variety of physiologic data streams in addition to the physical attributes of the mannequin itself; b) mannequins readily can portray abnormalities of physical examination, vital signs, and data through physiologic monitoring (the actors will rarely have such abnormalities themselves); c) mannequins, unlike actors, do not object to being poked with needles, having tubes inserted into bodily

orifices, receiving injected drugs, or suffering lethal diseases. Thus, when clinicians have a physical encounter with a patient beyond talking or rudimentary physical examination, a mannequin-based simulator will be needed.

Consequently, mannequin-based simulation is widely applicable among doctors, nurses, allied health professionals, and others at all levels of training and healthcare experience. Simulation can also be used with non-clinical personnel ranging from the lay public (school children or adults) to ancillary hospital personnel (facility assistants, housekeeping workers, etc.), managers, and executives. In addition, simulation has applications for organizational and political leaders as a mechanism to better acquaint them with the realities and difficulties of patient care. Finally, the application of simulation to patient education has not been fully explored.

While not an exhaustive list, anesthesia, intensive care, emergency medicine, neonatal healthcare, obstetrics, first responders (e.g., paramedics, EMTs),

catheterization laboratory, trauma care and nursing training have been among the most active areas of health care in using mannequin-based simulators. In these settings decisions about patient care can change suddenly and rapidly, and treatments often are potent, perhaps lethal. Further, life-threatening complications, though infrequent, must be managed promptly and effectively. Also, in these medical arenas complex interactions among a variety of specialized health care providers take place at an accelerated pace. The stress factor is high, and teamwork under pressure is critical. Further, since these patient settings challenge the ability of individual clinicians and teams to perform to perfection, they are also formidable domains for health care institutions striving to meet the demands of risk management and quality improvement. Not surprisingly, mannequin-based simulation has its roots and has flourished in these and other difficult health care settings where changing patient circumstances and prompt clinician reaction predominate. Often patients are awake and talking, and their history and verbal responses impact decision-making. Thus, using mannequin-based simulators as standardized patients willing and able to have serious diseases and undergo invasive therapies is a valuable asset for clinician training.

Purpose

The purpose of the activity is an important dimension of simulation application. Simulation can be used for education (learning of facts and concepts) and training (learning elements of the job). Simulation can also be used for performance assessment or for research. Research activities fall into two categories: a) research ABOUT simulation (e.g., making better simulators; developing new applications and pedagogical approaches; assessing learning outcomes;) and b) research that USES simulation as a tool to study the clinical process and performance issues (e.g., quality management, human factors).

Other Dimensions of Simulation Applications

The 11 dimensions of applications describe other important aspects of mannequin-based simulation (Figure 1), since the type of simulation modality is just one of the dimensions.

Unit of Participation

Unit of participation is another key dimension for mannequin-based simulation. Activities can be focused on individuals interacting one at a time with the simulator; on groups or teams (more on this below); or on larger entities such as work units (e.g., an entire ICU) or whole institutions (e.g., disaster drills where simulations involve entire hospitals, whole communities, or geographical regions). The decision on what unit of participation to include is again a trade-off between many different factors, and depends heavily on the purpose of the exercise and the logistical complexities of involving more participants or larger organizations.

Venue of Simulation - Relationship Between In-Situ Simulation and Dedicated Simulation Center

In the last five years, an important relationship has emerged between simulation activities that take place in a dedicated simulation teaching center versus those that take place in the actual clinical work environment. The latter is often referred to as “in-situ” simulation (Latin for “in place”). There are advantages and disadvantages to each approach. The advantages of in-situ simulation are: a) clinicians are probed and challenged in the workplace; b) equipment and supplies are used as they would be with real patients; c) the entire care process and system can be included in the simulation; and d) costs are lower than with a dedicated center, where construction capital and operational funding are required. In-situ simulation is especially useful for unannounced mock events that can both train individuals and teams and probe the effectiveness of an institution’s clinical operating systems.

In-situ simulation is available to any health care site that can acquire, rent, or borrow a simulator and provide appropriate instructors and ancillary gear. However, in-situ simulation has disadvantages. It may be difficult to schedule a functioning workplace site or to identify unused clinical spaces (e.g., an empty bay in the Emergency Department). Setting up a simulation in the workplace can be complicated and time-consuming, depending on the complexity of the planned activity. A simulation scheduled for an operational health care location may be preempted on short notice for actual patient care activities. Since personnel who are to take part in the simulation are in their actual clinical space, they may be easily distracted or asked to return prematurely to their clinical duties. In-situ simulations can be disruptive to

ongoing real patient care. Finally, since the clinical gear and supplies in an in-situ simulation are owned by the external institution, the costs of their usage may be considerably higher than that in a dedicated simulation center.

Simulations conducted in a dedicated facility also have advantages and disadvantages. While a dedicated center has the costs associated with space, construction, staff, and maintenance, once in place the facility allows for much greater control of simulation activities. By being separated from a real-life clinical practice site, the simulation center can more easily focus on its missions of teaching, assessment, and research. Participants can more freely attend to the simulation exercise and concentrate on the learning tasks. Scheduling is more efficiently arranged, and the necessary simulation and clinical equipment and supplies can be easily pre-set.

As a result of limited resources, small institutions may only be able to offer in-situ simulations. However, they may choose to partner with a nearby simulation center for needed activities. Due to the complementary relationship of the two approaches, larger sites are increasingly choosing to do both – i.e., creating a dedicated simulation center (or even a consortium of centers) that can also serve as a repository of experts who can oversee in-situ simulations.

As suggested above, any simulation (and particularly in-situ simulations) can be conducted either as a scheduled activity or as an unannounced mock event. When systematic training is the primary goal, it is usually best to schedule simulation activities so that all learners can be cycled through the training sessions in an efficient manner. Unannounced events most closely resemble real clinical challenges and are best when the primary goal is systems-probing.

Modes of Teaching with Mannequin-Based Simulations

The simulator is a tool to allow instructors to provide learning experiences for participants. For activities that aim to deliver education or training, there are different ways that teaching can be done before, during, and after the simulation session itself.

Figure 4. Teacher discussing the simulation activity.



Instructor-modeled: a scenario can be run in which the instructor performs all the clinical tasks to demonstrate the procedures, patient interactions, and the decision-making process.

A logical process of preparing and briefing learners nearly always is needed for best results in simulation training. Even for unannounced mock events, those likely to be asked to participate need prior explanation of the ground rules and techniques. Use of adjunctive learning modalities such as readings, videos, on-screen simulations, role-plays, or seminar discussions are commonly part of simulation activities.

During the simulation scenario there are many ways to conduct teaching.

- Participants completely on their own: participants work as if they were in a real clinical case with no direct intervention or teaching by the instructors. In many cases this will be followed by a debriefing session – i.e., dedicated time to review the scenario that just occurred and extract important lessons (more on debriefing below).
- Teacher-in-the-room: an instructor is in the simulation with the learners. The degree of involvement of the instructor with the learners can vary. A common mode of teaching when a teacher is in the room is “pause and reflect”. The ability of the simulator to be paused at a specific clinical point allows learners to discuss among themselves and with the instructor the pros and cons of available alternatives. Similarly, continuous discussion can take place while the simulation scenario is underway (real-time advice).

Which modes of teaching to use depends on a number of factors. For novices, it is almost a necessity to use instructor modeling and/or teacher-in-the-room techniques for most exercises. As the experience level of participants increases, the emphasis is

frequently on learners working on their own or as a small group without real-time instructor advice. Participants can seek advice from whatever sources they might access during real clinical care. Pause and reflect can be used with experienced personnel, especially when the clinical topic is novel for participants. Many simulation curricula mix different techniques for various activities in the same “course.”

Debriefing

Post-simulation debriefing has been used for nearly 20 years in some types of courses involving mannequin-based simulation. This practice was adopted from commercial aviation simulation courses. The purpose of debriefing sessions is to highlight key lessons from the simulation experience. There are a number of articulated formulas or styles of debriefing (e.g., Plus Delta; Debriefing with Good Judgment; Alternatives/Pros & Cons), but in general they all explore and evaluate with participants the alternatives they had at various junctures of the scenario.^{7,8} Debriefing sessions also draw out what went well and what did not, and what lessons can be extracted. Debriefing is different from feedback in that the former places greater emphasis on participant-driven discussion and more inquiry/advocacy whereas feedback is more instructor-driven transfer of information or critique. Most debriefing sessions combine instructor reaction and response with participant-led discussion.

When sessions are conducted in a dedicated simulation center, there is often an audio-video recording of the simulation scenario that can be used in debriefing. The extent to which video is used varies greatly with factors such as time available, video quality, purpose of the exercise, and instructor experience with video-based debriefing. On the one hand, video is a rich source of data as to what actually transpired versus the biased and faulty recollections of participants. On the other hand, much of what is captured on video may not be beneficial to watch, and debriefing time might be better spent with discussion. There are some empirical data suggesting that any debriefing is better than no debriefing, but that video-based debriefing is not superior to that without use of video. Simulation leaders who are experienced at debriefing tend to use video sparingly when the participants are actively engaged in discussing key points of the training exercise. When learners are

less engaged in the discussion or when there are critical questions about what happened, more extensive viewing of the video is justified. For research purposes the videos of simulation exercises are invaluable.

Other methods of debriefing include self-report using the paper-and-pencil format or Internet-based questionnaires; use of post-hoc blogs or diaries; and having participants debrief as a group without a facilitator. There are few data on the comparative effectiveness of debriefing techniques, but experts believe that for complex scenarios targeting higher level decision-making skills, a post-scenario debriefing is an important component of learning.

Simulation for Technical Skill vs. Non-Technical Skills

Simulators (and part-task trainers) can be used to address specific psychomotor skills of invasive procedures or technical decisions (e.g., “What is the right drug and dose for treating pulseless electrical activity [PEA]?”). Other sections of this compendium deal more thoroughly with part-task trainers and with on-line and on-screen simulators. Learning from the experience of aviation, a key early advance in mannequin-based simulation was the realization that the rate limiting step in many challenging clinical situations is not technical skills or patient-related decisions, but rather, behavioral skills (sometimes called non-technical skills). Non-technical skills can be categorized as either a) skills of dynamic decision-making (e.g., anticipation and planning, use of cognitive aids, avoiding fixation errors) or b) skills of teamwork and team management (e.g., workload distribution, communication, and/or role clarity). Since the whole patient is portrayed, the mannequin-based simulator can be used for the entire spectrum of target skills, whether technical or non-technical. Compared to role-playing, which many participants view as abstract, simulation involving non-technical skills takes place in the context of the full scope of clinical work.

A curriculum that is 60% or more behavioral and 40% or less medical/technical has come to be known as Crisis Resource Management (CRM). Crisis Resource Management began in Anesthesia almost 20 years ago and has spread to other domains of health care.^{9,10} The health care CRM simulation approach was modeled

after Crew (originally “Cockpit”) Resource Management in commercial aviation.^{11,12} The term “crew” or “cockpit” was changed to “crisis” to keep the same acronym, but to be applicable to healthcare. Crisis Resource Management has become a generic term for courses that address the principles of CRM using simulation.

There are many different reformulations of aviation’s CRM for healthcare; many do not use simulation. Others, such as TeamSTEPPS™, began without simulation, but a number of sites are exploring adding simulation to previously non-simulation courses. Currently, there is an explosion of simulation-based CRM (or teamwork) oriented curricula. No single formulation of CRM has proven to be perfect, nor is any one CRM simulation curriculum ideal for all settings. Thus, it is necessary to match program goals and learner needs with elements of curricular design to achieve an optimal result.

Team Training – Relationship Between Single Discipline and Combined Team Training Paradigms

Training clinicians about CRM and teamwork is complex. There is a relationship between simulation training courses that address teamwork issues in a single discipline (say, anesthesiologists or intensive care nurses) versus those that address multidisciplinary teams made up of those who work together. Each approach has advantages and disadvantages.

In the single discipline approach, the training curriculum is focused on a single specialty, although the simulation scenarios may have all team members present (played either by instructors, actors, or other participants in the simulation course) in a fully interactive fashion. Courses for a single discipline allow concentration on CRM issues and problems of greatest relevance to that discipline. Single discipline sessions are typically easier to schedule since only one department is involved. In such courses a greater diversity of co-worker types and personalities can be portrayed than in combined team exercises. By carefully scripting the roles of the simulation participants who are not members of the target discipline, the learning experience can be enhanced for the specialists for whom the training is designed. The disadvantage of single discipline simulations is that the participants are not a real-life team, and interactions can be somewhat artificial. Training sessions for combined teams of

health care professionals who work together are often more realistic and more readily accepted by participants.

Training activities for groups who work as teams in real-life practice have two principal advantages. First, multidisciplinary involvement in simulation activities creates cross-discipline awareness of goals and issues. Second, in combined team exercises participants can exchange roles, a teaching technique that enhances the appreciation of the skills of colleagues. For example, during simulations nurses can be doctors or vice versa. “Walking a mile” in someone else’s shoes can be a productive learning strategy. While it cannot be allowed in real patient care, cross-role experimentation has become a powerful simulation technique.

Combined team training has disadvantages as well. First, scheduling a variety of specialists can be more difficult than single discipline arrangements. Second, it is usually a challenge to create credible simulation content for all participating discipline. For example, it is easier to prepare and script anesthesiology scenarios than surgery activities since the latter has only a few operations and procedures for which simulators are available. These factors and the different personalities and modes of action of the different disciplines can make scripting realistic scenarios difficult.

It would be ideal for health care personnel wanting to develop or improve their clinical CRM skills to participate in both single discipline simulations and combined team simulation experiences over the course of a career.

Summary and Conclusions

Mannequin-based simulation is probably the most extensively utilized modality among the simulation approaches currently found in health care education today. Despite 20 years of continuous effort in this field, the trajectory for acceptance in using mannequin simulation to train and teach has been steep in the past 5-10 years. Since mannequin-based simulations have a wide range of uses, it would be naïve to delineate a few best practices. Careful consideration is required to match simulation pedagogy and curriculum to a program’s specific needs, goals, and target population(s).

The empirical evidence for the effectiveness and cost-benefit of mannequin-based simulation is limited. For some questions we may never be able to prove definitively with Level 1A evidence whether mannequin-based simulation saves lives, organs, or money.^{16,17} Nonetheless, the adoption of simulation for the training of health care professionals has taken root as a sensible evolution from the traditional system of lecture and apprenticeship, the staples of medical education for more than a century.

References

1. Abrahamson S, Denson JS, Wolf RM. Effectiveness of a simulator in training anesthesiology residents. *J Med Educ* 1969; 44:515-519.
2. Gaba DM. The future vision of simulation in healthcare. *Simul Healthc* 2007; 2:126-135.
3. Gaba DM. What's in a name: A mannequin by any other name would work as well. *Simul Healthc* 2006; 1:64-65.
4. Dieckmann P, Gaba D, Rall M. Deepening the theoretical foundations of patient simulation as social practice. *Simul Healthc* 2007; 2:183-193.
5. Scerbo MW, Dawson S. High fidelity, high performance? *Simul Healthc* 2007; 2:224-230.
6. Rudolph JW, Simon R, Raemer DB. Which reality matters? Questions on the path to high engagement in healthcare simulation. *Simul Healthc* 2007; 2:161-163.
7. Fanning RM, Gaba DM. The role of debriefing in simulation-based learning. *Simul Healthc* 2007; 2:115- 125.
8. Rudolph J. There's no such thing as "nonjudgmental" debriefing: a theory and method for debriefing with good judgment. *Simul Healthc* 2006; 1:49-55.
9. Howard S, Gaba D, Fish K, et al. Anesthesia crisis resource management training: teaching anesthesiologists to handle critical incidents. *Aviat Space Environ Med* 1992; 63:763-770.
10. Gaba D, Howard S, Fish K, et al. Simulation-based training in anesthesia crisis resource management (ACRM): a decade of experience. *SimulGaming* 2001; 32:175-193.
11. Helmreich R. Theory underlying CRM training: psychological issues in flight crew performance and crew coordination. In: Orlady HW, Foushee HC, eds. *Cockpit*

- resource management training (NASA Conference Publication 2455). Washington, D.C.: National Aeronautics and Space Administration; 1986:15-22.
12. Helmreich R, Foushee H. Why crew resource management? In: Weiner E, Kanki B, Helmreich R, eds. Cockpit resource management. San Diego: Academic Press; 1993: 3-46.
 13. Turner R, Scerbo M, Parodi A. Simulation as a means of enhancing healthcare teams training: DoD TeamSTEPPS at Naval Medical Center Portsmouth, VA. Presented at the Simulation in Healthcare Annual International Meeting, January 2010, Phoenix, AZ.
 14. Gaba D, Howard S, Fish K, et al. Simulation-based training in anesthesia crisis resource management (ACRM): a decade of experience. *Simul and Gaming* 2001; 32:175-93.
 15. Rall M, Gaba DM, Dieckmann P, et al. Patient simulation. In: Miller RD, ed. *Miller's anesthesia*. Philadelphia, PA: Churchill Livingstone; 2010: Chap 7.
 16. Gaba DM. The future vision of simulation in healthcare. *Simul Healthc* 2007; 2:126-135.
 17. Gaba DM. Out of this nettle, danger, we pluck this flower, safety: healthcare vs. aviation and other high-hazard industries. *Simul Healthc* 2007; 2:213-217.

About the Authors

David M. Gaba, MD is Associate Dean for Immersive and Simulation-based Learning and Director of the Center for Immersive and Simulation based Learning (CISL) at Stanford University School of Medicine. He is Professor of Anesthesia at Stanford and Director of the Patient Simulation Center of Innovation at Veterans Affairs Palo Alto Health Care System where he is also a Staff Anesthesiologist. He is a pioneer in the development of the modern full-body patient simulator and in the application of organizational safety theory to health care and is responsible for introducing Crew Resource Management training from aviation to healthcare, first in anesthesia and then to many other healthcare domains. He is a prolific author and researcher with an international reputation. After serving on the editorial boards of several high profile academic and medical journals, Dr. Gaba is now the founding Editor-in-Chief of the peer-reviewed journal *Simulation in Healthcare*, the official journal of the Society for

Simulation in Healthcare (SSH) and an official journal of the Society in Europe for Simulation Applied to Healthcare (SESAM)

Sandra J. Feaster, RN, MS, MBA is the Program Director of the Center for Immersive and Simulation based Learning (CISL) at Stanford University School of Medicine. CISL was created in 2005 as part of an initiative by the School of Medicine to combine and coordinate its many pioneering efforts in experiential and simulation learning. The Center includes the internationally recognized VA Simulation Group, Center for Advanced Pediatric and Perinatal Education – CAPE and the Goodman Simulation Center of the Department of Surgery and the newly built Immersive Learning Center (ILC). The ILC brings together all modalities of simulation and novel forms of immersion into one place to advance the medical education of students and others. She serves as Co-Chair of the American College of Surgeon’s Surgical Education Administration and Management Committee of the Consortium of ACS-accredited Education Institutes and is a member of the Board of Trustees of Saint Mary’s College of California.

Task Trainers and Haptics

Andrew S. Wright and Carlos A. Pellegrini

Introduction to Task Simulation and Available Technology

While the science of healthcare simulation is relatively new, simulators in the most basic form have been used for centuries. A simulator is simply a surrogate for the real, and can take many and varied forms. In the past, physicians and other health care workers learned new skills through practice with models such as cadavers, tissue blocks, or animal laboratories. This practice was typically informal, and not necessarily integrated into an overall education curriculum. In the more recent past, healthcare simulation has progressed as a discipline,¹ and is now becoming a requirement for residency education, board certification, and in some cases for maintenance of certification.

While simulation can be used for team training and building communication skills, its most common application has been in training, practice, and assessment of specific psychomotor skills. Each health care specialty has its own roster of such psychomotor skills that must be acquired by a trainee.²⁻³ Additionally, established healthcare workers must maintain psychomotor skills and acquire new skills in response to changing practice needs and the introduction of new procedures or technology. The ultimate goal of task simulation is the transfer of a learned psychomotor skill from the laboratory to the clinical environment.⁴

Psychomotor skills can be divided into a hierarchy of: (1) technical skills, (2) complex tasks, and (3) complete procedures.⁵ Technical skills are basic techniques, such as knot-tying or suturing. Complex tasks require the integration of technical skills (i.e., the technical skills of knot-tying and suturing are both used in the more complex task of wound closure). Complete procedures require multiple complex tasks. For example, colectomy requires the combination of multiple complex tasks including laparotomy, bowel resection and bowel anastomosis, and wound closure. Psychomotor skills at all levels include both a technical component (manual ability to perform the task) and a cognitive component (conceptual understanding of the task, its application in practice, and recognition of proper performance and errors).

The specific approach to training a new skill depends on the audience, the learning objectives, and the skill to be taught. Early in medical simulation the emphasis was on the **simulator** – the physical or virtual reality model - as opposed to the **simulation**. The simulation itself should be grounded in an understanding of the strengths and weaknesses of simulation as an educational intervention, and should include a sound educational curriculum, cognitive instruction, practice of a technical skill or task in a simulated environment, and formal assessment of performance.

Simulation Theory

The essence of simulation is that learners can practice new skills in a safe environment. This has several significant components. First, **deliberate practice** is essential for development of expert proficiency.⁶ Second, simulation offers an explicit **permission to fail**. In the modern era, mistakes are no longer tolerated in the clinical arena. Therefore, learners do not learn how to recognize errors, or to correct mistakes. This results in rigid thinking and an inability to adapt. In simulation learners are allowed to make mistakes and thus learn to recognize and recover from these errors.

Third, simulation allows for **assessment**. In the past, trainees have been evaluated subjectively or have been promoted simply on the basis of time spent in training or number of procedures completed. The amount of time spent is clearly a poor marker of performance – some individuals may learn within a few repetitions, while others need more time and practice. Simulation offers built-in assessment tools that can be used to certify the competency of learners, creating an environment where learners **train-to-proficiency**,⁷ rather than an arbitrary number of repetitions.

These same assessment tools allow **feedback** to the learner. Feedback can be **formative** or **summative**. With formative feedback, information about performance is given to the learner immediately, allowing him/her to incorporate constructive criticism and improve performance. With **summative** feedback, information is provided to the learner at the end of training and used to make a decision about his/her status or advancement.

Even basic technical skills have both a cognitive and a psychomotor component. When learners attempt a new skill in a clinical environment, such as the operating

room, **attention** is split, and the learner has a difficult time managing both components. By training in a simulated environment, psychomotor skills can be learned to **automaticity**, thereby allowing more attention in the clinical environment to be spent on cognitive functions (situational awareness).⁸

Lastly, simulators can be designed to present both **variations of normal** and **unusual or emergent situations**, allowing learners to be exposed to clinical scenarios that are uncommon in clinical training.

Types of Available Task Simulators

Commercially available simulators can be roughly classified into a number of types.

Mechanical simulators are the simplest, and are often constructed to teach discrete tasks (Figure 1). Examples include knot-tying boards, artificial tissue blocks for suturing practice, and box trainers for laparoscopy. While many companies produce such simulators, two leaders in this arena are Simulab (Seattle, WA) and Limbs & Things (Savannah, GA). Costs for these trainers are relatively low and range from a few dollars to several hundred dollars.

Figure 1. Mechanical simulators.

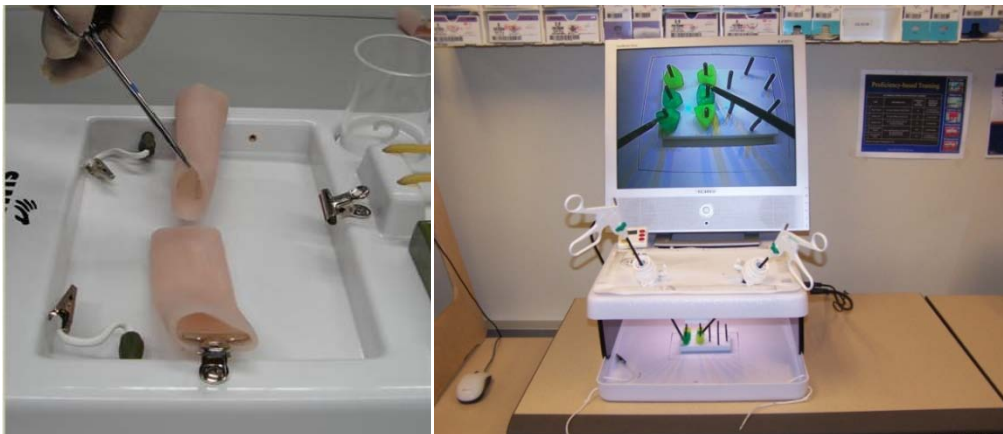

Left: Surgical skills training with simulated bowel (Simulab, Seattle, WA).

Right: With laparoscopic box trainer (Fundamentals of Laparoscopic Surgery, Los Angeles, CA).

Mannequin simulators were among the first to be developed. These are essentially dolls that represent the anatomy of specific organ systems, and may be used for such task simulations as airway management, childbirth, central venous catheterization, trauma resuscitation, and cholecystectomy (Figure 2). Typically, neither mechanical

nor mannequin simulators have integrated assessment tools; therefore, any assessment requires external review – usually a checklist or expert evaluation.

Figure 2. Mannequin simulators.

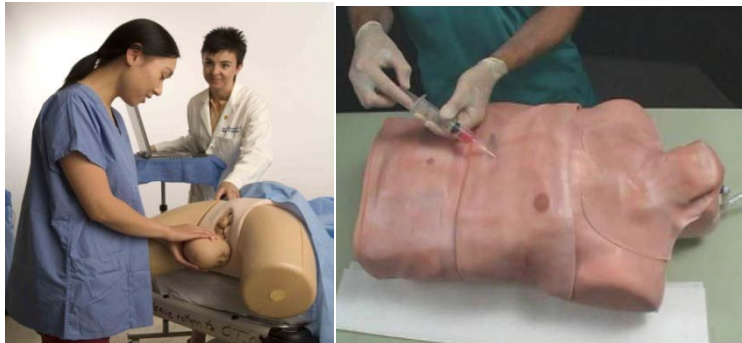

Left: Birthing simulator (Limbs & Things, Savannah, GA).

Right: TraumaMan (Simulab, Seattle, WA).

Virtual Reality (VR) trainers use computer based programs to simulate the real environment (Figure 3). The LapSim (Surgical Science, Göteborg, Sweden) and the GI Mentor (Symbionix, Cleveland OH) are examples. Costs for these simulators may be quite high – ranging from the tens of thousands to over a hundred thousand dollars depending on features. The great advantage of VR simulators is that they have built-in assessment metrics – e.g., a VR laparoscopy trainer may automatically record and report metrics such as time, errors, instrument path length, precision, and smoothness.

Figure 3: Virtual Reality Trainer

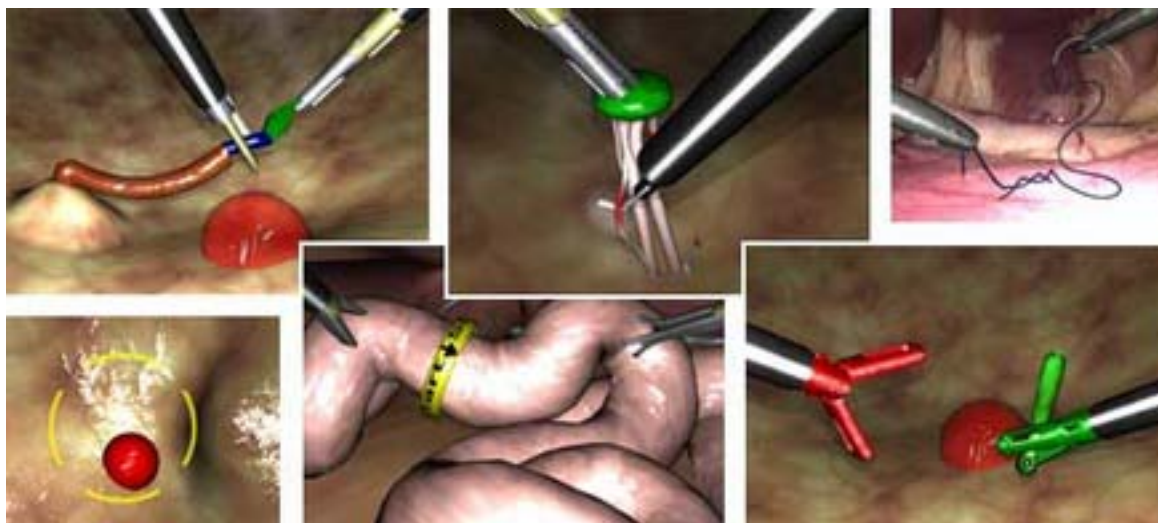

Images from the basic laparoscopy module of LapSim (Surgical Science, Göteborg, Sweden)

Cognitive simulators are used for training didactic information or rehearsing clinical scenarios. These are often screen-based, and may teach the steps of a procedural task but do not actually require physical performance of the task. As an example, the SimPraxis laparoscopic cholecystectomy trainer (Red Llama, Seattle, WA) breaks down a single operation into multiple steps, focusing on the recognition of potential critical errors (Figure 4). A cognitive simulator is often used along with a psychomotor simulator to cover both cognitive and technical aspects of the same task. The cost of cognitive simulators range widely, as many are developed by and shared freely among academic institutions, while others are commercial products with per-user license fees that may be as much as a few hundred dollars per seat.

Figure 4. Cognitive simulator.

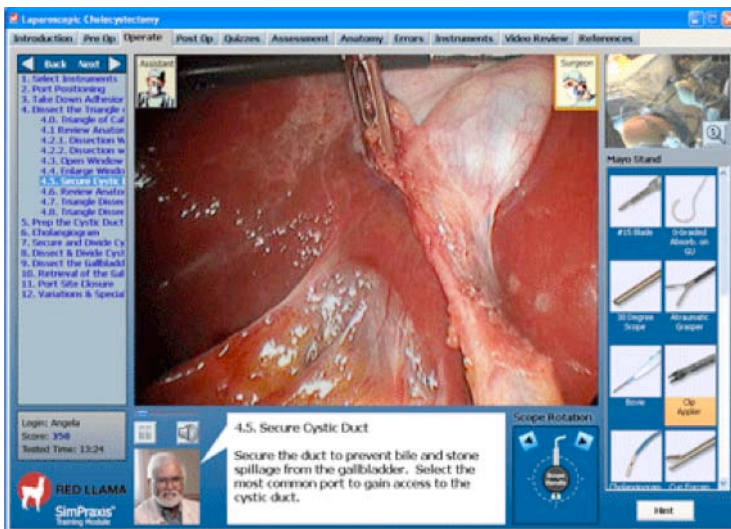

SimPraxis laparoscopic cholecystectomy cognitive trainer.

Hybrid simulators incorporate components of multiple simulator types. For example, the Simulab Edge (Seattle, WA) is a mechanical box trainer that also incorporates position and force sensors, allowing for computerized assessment of surgical performance and delivery of feedback to the learner. Similarly, the ProMIS laparoscopic simulator (Haptica, Dublin, Ireland) augments a physical box

trainer with VR, reality video overlays, and optical position-sensing of surgical instruments. As another example, human patient simulators such as the METI iStan (Sarasota, FL) are mannequin simulators with complex arrays of sensors and actuators. These allow the human patient simulators to have appropriate physiologic responses to events such as anesthesia, to respond to drug administration, and to record user activities for later review.

Haptics

Haptics refers to the sense of touch or force. We consciously and unconsciously use haptic feedback from the real world to help guide interventions – for example, a obstetrician may use a sense of force to know exactly how hard to manipulate a fetus during delivery to avoid shoulder dystocia. Mechanical simulators have inherent haptic feedback, as they use real objects to simulate a task. Therefore, the realism of a mechanical simulator depends on the properties of the physical model. A tissue block may feel more or less like skin depending on the chosen material. On the other hand, pure VR simulators have no force feedback or haptics, as the environment is entirely generated within the computer. Consequently, many VR simulators incorporate mechanisms to provide the learner with haptic feedback through special interfaces and equipment. While intuitively appealing, the addition of haptic feedback adds significantly to the cost and complexity of a VR simulator.

Van der Meijden and Schijven recently conducted a systematic review of haptics in surgical simulation and robotic-assisted surgery.⁹ In theory, haptics are important for training procedures in which significant forces are applied.¹⁰ Without haptic feedback a trainee may learn to use inappropriate levels of force. When translated to the clinical arena, this could lead to patient injury. There is limited evidence that the integration of haptics into laparoscopic trainers improves the early acquisition of technical skills,¹¹ and, in general, the evidence for haptics in surgical simulation is limited (level of evidence 3b or less). Further, there is no evidence that links haptics in training to improved clinical outcomes⁹ or to cost-effectiveness.

High vs. Low Fidelity

Fidelity refers to the extent to which a simulator accurately reflects the real world.¹² Low-fidelity simulators are not designed to be realistic, but to be adequate to teach a particular skill. On the other hand, higher-fidelity simulators may incorporate technologies such as virtual reality, computer-based control mechanisms, or haptics to heighten the simulated reality. While high-fidelity simulation is intuitively appealing, the downside is increased cost and complexity. Additionally, high fidelity may not be necessary in all situations.

In childbirth training, a randomized comparison of low- and high-fidelity mannequins showed significantly improved clinical outcomes in the high fidelity groups.¹³ Similarly, when compared to low-fidelity simulation, high fidelity simulation results in significantly improved training in Advanced Cardiac Life Support.¹⁴ In contrast, several studies have found no improvement in skill acquisition between high and low fidelity simulation, including trials in epidural anesthesia,¹⁵ learning heart sounds,¹⁶ and basic laparoscopic skills.¹⁷

In fact, low vs. high fidelity is likely a false dichotomy, with fidelity being a continuum from unrealistic to very realistic.¹⁸ The necessary level of fidelity, and the specific components of fidelity, may vary depending on the task at hand. Simple procedural tasks, such as suturing and knot-tying, may be learned very effectively with low-cost, lower-fidelity simulators such as laparoscopic box trainers. On the other hand, complex tasks, such as a complete laparoscopic cholecystectomy or management of critically ill patients, may need a much higher level of realism.

Application to Clinical Practice

Curriculum Design

Initial experience in healthcare simulation revolved around simulator development rather than curricular design. This resulted in many centers building or purchasing expensive high-fidelity virtual reality (VR) simulators that then sat underutilized because they were not incorporated into an overall educational plan. From this experience, we have learned that the first step must involve curriculum design, and the choice of simulation technology should be based on a sound understanding of educational needs.

The first step in curriculum design is determining the audience – medical students and novice learners have very different needs when compared to experienced clinicians who are learning a new technology. After determining the audience, the next step is to assess the needs of that audience and determine the goals of the educational curriculum. Then cognitive learning material related to the task should be developed (e.g., videos of the procedure of interest). Based on the needs of the learners, a simulator should then be acquired or developed. The lowest cost, simplest simulator should be chosen for the specific task. A simulation should also have defined

assessment metrics, again targeted to the educational goals. Finally, there should be a plan for assessing the validity of the training and for measuring the impact on learners' abilities or clinical outcomes.

As an example, at the University of Washington based on a hospital quality improvement process, we identified a need to train physicians on proper central venous catheterization practices. The audience was defined as all physicians who place central lines, including both residents and attending. We then defined the educational goals: compliance with the Institute for Healthcare Improvement central line bundle;¹⁹ understanding of anatomy; use of ultrasound; adherence to proper technique; and recognition and management of complications. We then developed an online cognitive trainer with text, photos, videos, flash animations, and examples, followed by a cognitive assessment test (Figure 5).

Figure 5. Central venous catheterization curriculum.

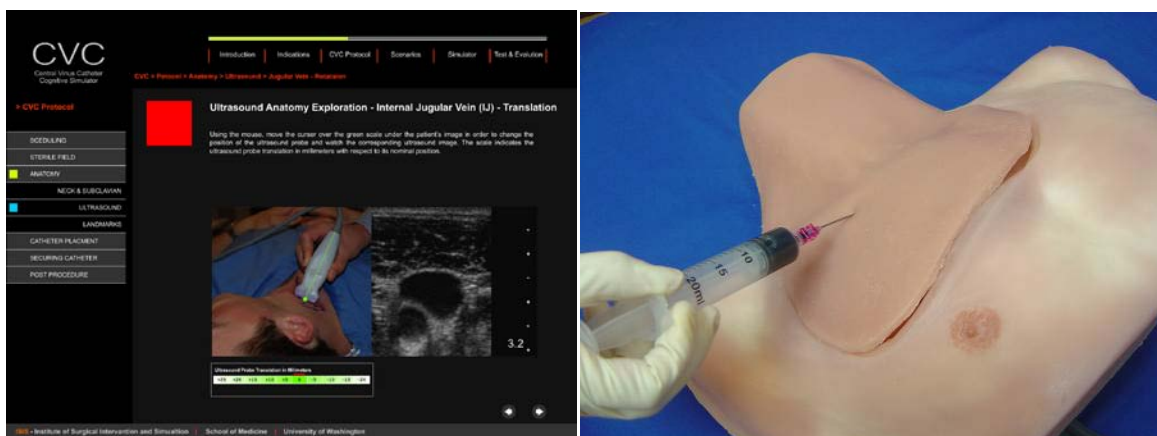

Left: Web-based module including rich multimedia such as interactive ultrasound images and video of procedural steps.

Right: Mannequin simulator for ultrasound-guided central line placement.

Based on our identification of the technical requirements of the task, we surveyed available task trainers, acquired mannequin-based central venous trainers, and designed a task simulation. The task simulation includes all steps identified by our needs assessment, including proper patient identification, sterile technique, use of ultrasound, placement of jugular and subclavian lines, and line dressing. Since no assessment tool existed for central venous catheterization, we developed a checklist-based assessment measure. Finally, we have a defined (and ongoing) process by

which we are both validating the simulation and, more importantly, measuring the impact of this training on the rate of adverse outcomes in our hospital system.

Integration into Training and Practice

A number of studies have shown that skills training in the simulation laboratory results in improved technical performance. Perhaps the best-studied simulation is the Fundamentals of Laparoscopic Surgery (FLS).²⁰⁻²² FLS consists of web-based cognitive training followed by practice and assessment of proficiency on five basic technical skills. It has been extensively validated, and performance on the FLS technical skills exam is highly correlated with intraoperative ratings of skill.²³ FLS training has also been shown to improved surgical performance – for example, Korndorffer et al. demonstrated that less than three hours of practice on the FLS simulator results in more than 100% faster performance in an *in vivo* suturing task with improved knot security and greater accuracy when compared to untrained controls.²⁴ Numerous other laparoscopic trainers (both mechanical and VR-based) have been studied and shown to result in improved performance.^{17,25-29}

Although task training has perhaps been best studied for laparoscopy, simulation-based skill training has been shown to improve performance in a number of other technical skills from multiple medical specialties. For example, Crofts et al. performed a randomized, controlled, multi-site study that linked training in a childbirth shoulder dystocia task to a significantly higher rate of successful simulated delivery – 94% compared to 72%.¹³ Task simulation has also been studied for endoscopy,³⁰⁻³² trauma care,³³⁻³⁴ open surgical skills training,³⁵ basic skills such as suturing and knot-tying,⁴ and endovascular procedures.³⁶

While most studies in simulation have examined skill acquisition in the laboratory environment, there is growing evidence that simulation results in improved clinical performance.³⁷ For example, Grantcharov et al. showed that VR-based laparoscopic training resulted in faster operative times and fewer errors when performing a laparoscopic cholecystectomy.³⁸ Similarly, Seymour et al. showed that VR-trained surgical residents are 29% faster and six times less likely to commit errors than non-trained controls.³⁹ Simulation-based training results in significantly fewer clinical

complications of central line placement.⁴⁰ VR-based endoscopy training results in significantly improved operator competence³¹ and better patient comfort levels.⁴¹

Due to the mounting evidence of its effectiveness, simulation is currently being integrated into, and in some programs required for, training in a number of medical and allied health specialties. As an example, the Association of Program Directors in Surgery (APDS) and the American College of Surgeons (ACS) have combined to develop a national technical skills curriculum for general surgical training (available at elearning@facs.org).⁴² This curriculum consists of three phases, the first two of which focus on task training. Phase I includes 20 modules based on basic surgical tasks such as asepsis, tissue flaps, and anastomotic techniques. Phase II has 15 modules on procedures ranging from laparoscopic Nissen fundoplication to open colectomy. Phase III focuses on team training and communication rather than procedural skills and includes 10 modules such as patient handoff and teamwork in the trauma bay. Each module consists of didactic information, instructions for the simulation, and assessment tools. Jensen et al. published a primer for the skin flaps and grafts module of the ACS/APDS core curriculum.⁴³ While this curriculum is currently suggested, rather than required, it is being rapidly adopted by many residency programs. In our own residency program at the University of Washington we have incorporated the ACS/APDS curriculum into our technical and professional skills curriculum, which includes weekly lectures and skills labs as well as a required annual rotation in the simulation laboratory.

The growing interest in simulation has also spurred the development of simulation laboratories at many centers worldwide. To enhance collaboration between centers, both the American College of Surgeons and the American Society of Anesthesiologists have developed programs to accredit simulation centers. The ACS has also founded a consortium of its accredited educational institutes.⁴⁴ Other groups actively involved in the promotion and dissemination of healthcare simulation include the Association for Surgical Education, the annual Medicine Meets Virtual Reality conference, and the Society for Simulation in Healthcare.

Evaluation and Outcome Measurement

Assessment

As described above, a major advantage of simulation-based task training is the availability of defined metrics for assessment of performance. There are many tools that are used as metrics. Perhaps the easiest to measure and acquire are time and error metrics, such as collected by the FLS.²³ In this model, the only equipment needed is a stopwatch and a checklist of common errors. Scoring can be completed by self-assessment or through external review by a trained, but not necessarily expert, reviewer.²¹ Time and errors can be converted through a numerical formula to an overall score that allows for the establishment of proficiency measures and even pass/fail rates.⁴⁵

One criticism of time- and error-based metrics is that they may miss important information about task performance, especially for more complex or delicate tasks. For example, a novice may be trained to perform a task quickly but may be rough with tissue or use undue and potentially dangerous force. An alternative approach is to acquire objective psychomotor performance data. This can be achieved in VR-based simulators where metrics such as path length, instrument smoothness, and force applied are easily generated. Physical simulators can also be adapted to provide such information. For example, the RedDRAGON is a laparoscopic box trainer that has been modified to include position and force sensors, thus allowing the concomitant acquisition of traditional time and error metrics as well as objective physical data. Results can be combined using advanced modeling techniques to create a portrait of surgical performance that distinguishes the novice from the expert surgeon.⁴⁶ The disadvantage of such systems is that they may be better at providing summative feedback than formative feedback – telling a trainee that her path length is too long may not be meaningful in the context of learning a new technique.

As an alternative, expert review and evaluation provide robust and useful formative and summative feedback. The expert can coach the trainee and also grade performance using structured assessment tools. Examples include the Objective Structured Assessment of Technical Skill (OSATS), which combines a task-specific checklist with global ratings of performance,⁴⁷ or the Global Operative Assessment of

Laparoscopic Skill (GOALS).⁴⁸ The disadvantage of expert review is that it tends to be somewhat subjective (making inter-rater reliability and review by multiple experts necessary). Expert review is also time-consuming and may be prohibitively expensive in terms of expert man-hours.

Choosing the appropriate assessment tool depends on the specifics of the simulation, and may vary depending on the goals and intended audience of the curriculum. For example, time and error metrics may be appropriate for simulations teaching basic psychomotor skills that rely on self-guided learning. On the other hand, training in complex procedural tasks may benefit from expert review, coaching, and assessment.

Validity and Reliability

For an assessment tool to be used in a high-stakes setting, such as for promotion or credentialing, it must be valid.⁴⁹ Validity is the extent to which an assessment tool measures accurately what it is designed to measure. There are numerous types of validity⁵⁰⁻⁵¹ including **face** (the simulated tasks resembles the real), **content** (task contains the relevant subject material), **construct** (able to discriminate between levels of performance), **concurrent** (results correlate with other measures of same ability), and **predictive** (task performance predicts real-world performance). Reliability is the extent to which a measure is consistent across repeated tests,⁵² and includes **test-retest reliability** (correlation of tests applied more than once to same subjects), **internal consistency** (correlation of subsets of scores measuring same construct), and **inter-rater reliability** (degree of agreement between multiple raters of same test subjects).

It is important to note that studies in healthcare simulation have used many different definitions of validity and reliability, and the framework for establishing validity has changed over the years. Additionally, studies that purport to “validate” a particular simulator or assessment tools are often limited in terms of subject population and may or may not be generally applicable. In a recent review of 83 validation studies in general surgery, we found that 1) fewer than half of the studies reported reliability data, 2) 60% examined only construct validity, 3) most did not provide a rationale for the measures selected, 4) 82% were limited to a single institution, and 5) the mean number of subjects was only 37.⁵² Thus, lack of standardized validation

methodologies hampers the generalizability of assessment tools and limits the ability to use such tools for high-stakes purposes such as proficiency-based advancement or credentialing.

Future Practice

As healthcare simulation improves and validation becomes more robust, we will begin to see simulation become a required, rather than a suggested, component of healthcare education. We can see this trend in the establishment of the ACS/APDS national technical skills curriculum in general surgery. A number of groups are working on establishing similar national curricula for other trainees, including medical students. Over time these curricula will no longer be optional, but documentation of proficiency will be required for promotion within training programs and eventually for graduation and certification.

As an example, the American Board of Surgery (ABS) now requires all candidates for board certification in general surgery to take and pass the FLS and Advanced Trauma Life Support (ATLS) course, both of which are simulation-based training programs. The ABS has also established maintenance of certification program for surgeons in practice. Although this does not yet require simulation-based documentation of proficiency, such requirements are likely in the future.

In addition to requiring simulation-based education for trainees, there is a growing movement to incorporate such training for physicians and healthcare workers in practice. For example, within our University of Washington hospital system all physicians who place central venous catheters are required to take and pass a simulation-based certification process to be credentialed for this procedure. As another example, CRICO/RMF, the insurance provider for the Harvard medical community, is offering financial incentives for practicing physicians who successfully complete FLS training. Kahol et al. have recently demonstrated that a brief warm-up period on a laparoscopic simulator results in improved surgical performance,⁵³ much as an athlete might warm-up prior to a game. Practicing healthcare workers may also benefit from simulation for the acquisition of new skills such as endovascular techniques³⁶ or for learning new technology such as single incision laparoscopy.

Cost

The cost of task simulation is difficult to assess, as most estimates include only the direct costs of the simulators. The in-kind donation of space from health systems or industry may not be included in budgets. In a recent survey of 34 simulation centers, estimates of startup costs ranged from “minimal” to more than \$3 million, with an average start-up cost of \$450,000.⁵⁴ Simulators themselves range in cost from a few dollars for a knot-tying board and suture to several hundred thousand for an advanced haptics-enabled virtual reality endoscopic simulator. The hidden cost in personnel is often overlooked. Frequently, faculty are not compensated for their time teaching in the simulation laboratory, leading to difficulties recruiting and retaining faculty. Additionally, time spent by trainees and faculty in the simulation laboratory is time away from potentially revenue-generating clinical activity. The development of a sustainable financial model for healthcare simulation is critical and a necessary step for future growth in education settings.

References

1. Satava RM. Historical review of surgical simulation - a personal perspective. *World J Surg* 2008; 32:141-148.
2. Mandel LP, Lentz GM, Goff BA. Teaching and evaluating surgical skills. *Obstet Gynecol* 2000; 95:783-785.
3. Langdale LA, Schaad D, Wipf J, et al. Preparing graduates for the first year of residency: are medical schools meeting the need? *Acad Med* 2003; 78:39-44.
4. Jensen AR, Wright AS, Levy AE, et al. Acquiring basic surgical skills: is a faculty mentor really needed? *Am J Surg* 2009; 197:82-88.
5. Satava RM, Cuschieri A, Hamdorf J. Metrics for objective assessment. *Surg Endosc* 2003; 17:220-226.
6. Ericsson KA. Deliberate practice and acquisition of expert performance: a general overview. *Acad Emerg Med* 2008; 15:988-994.
7. Gallagher AG, Ritter EM, Champion H, et al. Virtual reality simulation for the operating room: proficiency-based training as a paradigm shift in surgical skills training. *Ann Surg* 2005; 241:364-372.

8. Rehrig ST, Powers K, Jones DB. Integrating simulation in surgery as a teaching tool and credentialing standard. *J Gastrointest Surg* 2008; 12:222-233.
9. van der Meijden O, Schijven M. The value of haptic feedback in conventional and robot-assisted minimal invasive surgery and virtual reality training: a current review. *Surg Endosc* 2009; 23:1180-1190.
10. Chmarra M, Dankelman J, van den Dobbelsteen JJ, et al. Force feedback and basic laparoscopic skills. *Surg Endosc* 2008; 22:2140-2148.
11. Jacobs S, Holzhey D, Strauss G, et al. The impact of haptic learning in telemanipulator-assisted surgery. *Surg Laparosc Endosc Percutan Tech* 2007; 17:402-406.
12. Beaubien JM, Baker DP. The use of simulation for training teamwork skills in health care: how low can you go? *Qual Saf Health Care* 2004; 13 (1, Suppl.):i51-i56.
13. Crofts JF, Bartlett C, Ellis D, et al., Training for shoulder dystocia: a trial of simulation using low-fidelity and high-fidelity mannequins. *Obstet Gynecol* 2006; 108:1477-1485.
14. Rodgers DL, Securro SJ, Pauley RD. The effect of high-fidelity simulation on educational outcomes in an advanced cardiovascular life support course. *Simul Healthc* 2009; 4:200-206.
15. Friedman Z, Siddiqui N, Katznelson R, et al. Clinical impact of epidural anesthesia simulation on short- and long-term learning curve: high- versus low-fidelity model training. *Reg Anesth Pain Med* 2009; 34:229-232.
16. de Giovanni D, Roberts T, Norman G. Relative effectiveness of high- versus low-fidelity simulation in learning heart sounds. *Med Educ* 2009; 43:661-668.
17. Munz Y, Kumar BD, Moorthy K, et al. Laparoscopic virtual reality and box trainers: is one superior to the other? *Surg Endosc* 2004; 18:485-94.
18. Maran NJ, Glavin RJ. Low- to high-fidelity simulation - a continuum of medical education? *Med Educ* 2003; 37 (1, Suppl.):22-28.
19. Pronovost P, Needham D, Berenholtz S, et al. An intervention to decrease catheter-related bloodstream infections in the ICU. *N Engl J Med* 2006; 355:2725-2732.

20. Castellvi AO, Hollett LA, Minhajuddin A, et al. Maintaining proficiency after fundamentals of laparoscopic surgery training: a 1-year analysis of skill retention for surgery residents. *Surgery* 2009; 146:387-393.
21. Scott D, Ritter EM, Tesfay ST, et al. Certification pass rate of 100% for fundamentals of laparoscopic surgery skills after proficiency-based training. *Surg Endosc* 2008; 22:1887-1893.
22. Ritter EM, Scott DJ. Design of a proficiency-based skills training curriculum for the fundamentals of laparoscopic surgery. *Surg Innov* 2007; 14:107-112.
23. Fried GM, Feldman LS, Vassiliou MC, et al. Proving the value of simulation in laparoscopic surgery. *Ann Surg* 2004; 240:518-525.
24. Korndorffer JR, Jr, Dunne JB, Sierra R, et al. Simulator training for laparoscopic suturing using performance goals translates to the operating room. *J Am Coll Surg* 2005; 201: 23-29.
25. Aggarwal R, Moorthy K, Darzi A. Laparoscopic skills training and assessment. *Br J Surg* 2004; 91:1549-1558.
26. Stelzer MK, Abdel MP, Sloan MP, et al. Dry lab practice leads to improved laparoscopic performance in the operating room. *J Surg Res* 2009; 154:163-166.
27. Chaudhry A, Sutton C, Wood J, et al. Learning rate for laparoscopic surgical skills on MIST VR, a virtual reality simulator: quality of human-computer interface. *Ann R Coll Surg Engl* 1999; 81:281-286.
28. Hyltander A, Liljegren E, Rhodin PH, et al. The transfer of basic skills learned in a laparoscopic simulator to the operating room. *Surg Endosc* 2002; 16:1324-1328.
29. Haque S, Srinivasan S. A meta-analysis of the training effectiveness of virtual reality surgical simulators. *IEEE Trans Inf Technol Biomed* 2006; 10:51-58.
30. Clark JA, Volchok JA, Hazey JW, et al. Initial experience using an endoscopic simulator to train surgical residents in flexible endoscopy in a community medical center residency program. *Curr Surg* 2005; 62:59-63.
31. Cohen J, Cohen SA, Vora KC, et al. Multicenter, randomized, controlled trial of virtual-reality simulator training in acquisition of competency in colonoscopy. *Gastrointest Endosc* 2006; 64:361-368.
32. Gerson LB, Van Dam J. Technology review: the use of simulators for training in GI endoscopy. *Gastrointest Endosc* 2004; 60:992-1001.

33. Hammond J. Simulation in critical care and trauma education and training. *Curr Opin Crit Care* 2004; 10:325-329.
34. Lee SK, Pardo M, Gaba D, et al. Trauma assessment training with a patient simulator: a prospective, randomized study. *J Trauma* 2003; 55:651-657.
35. Reznick RK. Surgical simulation: a vital part of our future. *Ann Surg* 2005; 242:640-641.
36. Alderliesten T, Konings MK, Niessen WJ. Simulation of minimally invasive vascular interventions for training purposes. *Comput Aided Surg* 2004; 9:3-15.
37. Scott DJ, Cendan JC, Pugh CM, et al. The changing face of surgical education: simulation as the new paradigm. *J Surg Res* 2008; 147:189-193.
38. Grantcharov TP, Kristiansen VB, Bendix J, et al. Randomized clinical trial of virtual reality simulation for laparoscopic skills training. *Br J Surg* 2004; 91:146-150.
39. Seymour NE, Gallagher AG, Roman SA, et al. Virtual reality training improves operating room performance: results of a randomized, double-blinded study. *Ann Surg* 2002; 236:458-463.
40. Britt RC, Novosel TJ, Britt LD, et al. The impact of central line simulation before the ICU experience. *Am J Surg* 2009; 197:533-536.
41. Sedlack RE, Kolars JC, Alexander JA. Computer simulation training enhances patient comfort during endoscopy. *Clin Gastroenterol Hepatol* 2004; 2:348-352.
42. Scott D, Dunnington G. The new ACS/APDS skills curriculum: moving the learning curve out of the operating room. *J Gastrointest Surg* 2008; 12:213-221.
43. Jensen AR, Klein MB, Ver Halen JP, et al. Skin flaps and grafts: a primer for the national technical skills curriculum advanced tissue-handling module. *J Surg Educ* 2008; 65:191-199.
44. Sachdeva A, Pellegrini C, Johnson K. Support for simulation-based surgical education through American College of Surgeons – accredited education institutes. *World J Surg* 2008; 32:196-207.
45. Fraser SA, Klassen DR, Feldman LS, et al. Evaluating laparoscopic skills: setting the pass/fail score for the MISTELS system. *Surg Endosc* 2003; 17:964-967.
46. Rosen J, Solazzo M, Hannaford B, et al. Objective laparoscopic skills assessments of surgical residents using hidden Markov models based on haptic information and tool/tissue interactions. *Stud Health Technol Inform* 2001; 81:417-423.

47. Anastakis DJ, Regehr G, Reznick RK, et al. Assessment of technical skills transfer from the bench training model to the human model. *Am J Surg* 1999; 177:167-170.
48. McCluney A, Vassiliou MC, Kaneva PA, et al. FLS simulator performance predicts intraoperative laparoscopic skill. *Surg Endosc* 2007; 21:1991-1995.
49. Carter FJ, Schijven MP, Aggerwal R, et al. Consensus guidelines for validation of virtual reality surgical simulators. *Surg Endosc* 2005; 19:1523-1532.
50. Satava RM, Gallagher AG, Pellegrini CA. Surgical competence and surgical proficiency: definitions, taxonomy, and metrics. *J Am Coll Surg* 2003; 196:933-937.
51. Gallagher AG, Ritter EM, Satava RM. Fundamental principles of validation, and reliability: rigorous science for the assessment of surgical education and training. *Surg Endosc* 2003; 17:1525-1529.
52. Van Nortwick SS, Lendvay TS, Jensen AR, et al. Methodologies for establishing validity in surgical simulation studies. *Surgery* 2010; 147:622-630.
53. Kahol K, Satava RM, Ferrara J, et al. Effect of short-term pretrial practice on surgical proficiency in simulated environments: a randomized trial of the "preoperative warm-up" effect. *J Am Coll Surg* 2009; 208:255-268.
54. Kapadia MR, DaRosa DA, MacRae HM, et al. Current assessment and future directions of surgical skills laboratories. *J Surg Educ* 2007; 64:260-265.

About the Authors

Andrew S. Wright, MD is a core faculty member of the Institute for Simulation and Interprofessional Studies (ISIS) at the University of Washington. He holds an appointment as Assistant Professor of Surgery at the University's School of Medicine. ISIS has as its primary goal to provide leadership in the use of simulation technologies to improve the quality of health care education and improve patient safety and outcomes. Research and simulators development at ISIS is part of a collaborated effort between ISIS expert group, the Biorobotics Lab (BRL), and the Human Interface Technology lab (HIT Lab) at the University Of Washington. Dr. Wright has particular interests include bariatric surgery, anti-reflux surgery and surgery for the stomach and colon cancer. His current research is concentrated in skills acquisition in single

incision laparoscopic surgery and other innovations in surgical technology including surgical robotics.

Carlos A. Pellegrini, MD is Chairman of the Board of Directors of ISIS and chair of the Department of Surgery at the University of Washington School of Medicine. He holds an appointment as Professor and the Henry N. Harkins Endowed Chair in Surgery. At the University of Washington he developed the Center for Videoendoscopic Surgery, the Swallowing Center and the Institute for Surgical and Interventional Simulation (ISIS). Currently, he is Vice-Chair, Board of Regents of the American College of Surgeons, a Director of the American Board of Surgery, and Chair of the Digestive Disease Week Council and a past-president of the American Surgical Association. He serves on several editorial boards and publishes regularly in the field of minimally invasive surgery for upper gastrointestinal diseases, esophageal cancer, and related areas, as well as the field of training and new technologies for preparing surgeons in this area.

Standardized Patients

Rachel Yudkowsky and Benjamin Blatt

Standardized patients (SPs) are persons who are trained to portray a given patient presentation in a consistent and believable manner, allowing the realistic simulation of patient encounters.^{1,2} SPs can be recruited from a range of backgrounds including professional actors, retired teachers, community volunteers, patients with stable physical findings, nurses, medical residents and students. By providing controlled, high-fidelity simulations of clinical encounters and conversations, standardized patients can enrich the instruction and assessment of competencies such as communication with patients, family, staff and colleagues; history and physical exam skills; clinical reasoning and decision making; ethical and professional behavior; and procedural skills. Standardized patients contribute to patient safety by allowing learners to practice rare or high-risk conversations in a controlled environment and by ensuring proficiency before learners approach real patients. Uniquely, SPs provide the opportunity for detailed feedback from the perspective of the patient, promoting patient-centered care.

The key to SP effectiveness is a realistic, consistent portrayal of the patient. The *SP script* contains the details of the portrayal. The script stipulates the age, gender, and other salient characteristics of the patient and describes the patient's medical history and physical exam findings - i.e., their "backstory" (family, job and life circumstances), their personality and affect. The script also specifies information to be provided in response to open ended questions, information to be given only if specifically elicited by the examinee, SP prompts for the examinee (e.g., SP questions such as: "Can I go home now?"), and the desired SP responses to different examinee behaviors. The extent and richness of the script depend in part on the length and nature of the expected interaction. A five-minute encounter in which a student examines the shoulder of the SP without gathering any historical information may require only a description of physical exam findings to be simulated (if any). A 30-minute encounter in which an examinee is asked to develop a differential diagnosis and treatment plan for a depressed elderly woman demands a highly detailed and elaborated script.

SP scripts should be written by teams of experienced clinicians, preferably based on their own experiences with an actual patient, with modifications to maintain patient confidentiality. Basing the script on a real patient provides the foundation for a rich backstory, supporting details such as laboratory results, and the assurance that the script “hangs together” to present a plausible and realistic patient. Figure 1 lists elements of an effective script suggested by the Association of Standardized Patient Educators and provides a template or scaffold for the needed information. SP scripts for a variety of presenting complaints and communication tasks can be found in published casebooks^{3,4} and in online resource banks such as MedEdPortal (www.aamc.org/mededportal)⁵ and the Association of Standardized Patient Educators (www.aspeducators.org).⁶

SP training: When the script is available, an SP can be trained to portray the patient accurately, consistently, and believably.⁷⁻¹⁰ Training includes review, clarification and memorization of the case material, followed by rehearsal of the material in simulated encounters with the trainer and/or simulated examinees. The SP must be able to improvise appropriately and in character when confronted with unexpected questions from the examinee. If more than one SP will be portraying the same case, training them together will promote consistency across different SPs. If SPs will be providing verbal or written feedback to the examinee, they should be trained to do so effectively.⁵ If SPs will be rating the examinees, this requires training as well (discussed below). The entire training process can range from 30 minutes to eight hours and more, depending on the complexity of the script and the responsibilities of the SP.

Teaching with Standardized Patients

Kolb characterized learning as a cyclical process in which learners enter the learning setting, experience successes and frustrations, reflect upon their experiences, synthesize new approaches, and then re-enter the learning setting to put these approaches to the test.¹¹ SPs can serve as valuable teaching colleagues in each phase of this cycle of learning - experience, reflection, synthesis, re-experience. From an instruction perspective, SP-based experiences have some advantages over those

Figure 1. Essential elements of a Standardized Patient case.

General Case Information

- Presenting complaint
- Diagnosis
- Case author contact information
- Learning objectives, competencies addressed in case
- Target learner group (e.g., medical students, residents, nursing students, nurse practitioner students)
- Level of learner (year of training, advanced clinician, etc.)
- Duration of patient encounter

○ **Case Summary and SP Training Notes**

- SP demographics: name, gender, age range, ethnicity
- Setting (clinic, ER, etc.)
- History of present illness
- Past medical history
- Family medical history
- Social history and backstory
- Review of systems
- Physical examination findings (if indicated)
- Special instructions for the SP:
 - Patient presentation (affect, appearance, position of patient at opening, etc.)
 - Opening statement
 - Embedded communication challenges
 - Responses to open-ended questions
 - Responses to specific interviewing techniques or errors
- Special case considerations/props:
 - Specific body type/physical requirements
 - Props (e.g., pregnancy pillow)
 - Make-up (please include application guidelines, if available)

○ **Additional Materials:**

- Door chart information
- Laboratory results, radiology images (if indicated)
- Student instructions
- Student pre- or post-encounter challenge
- SP checklist or rating scale for scoring the encounter
- Observer checklist or rating scale
- SP feedback guidelines
- Other supporting documents (faculty instructions, etc.)

Adapted with permission from the Association of Standardized Patient Educators (ASPE)

with real patients, since educators can control SP characteristics to design encounters that best suit the educational objectives of the course and the level of the learner.

After the learning experience (i.e., the encounter with the SP), SPs can take on an active teaching role by providing learners with feedback to trigger reflection and synthesis. Feedback is a powerful method to catalyze reflection and synthesis, and SPs who are trained appropriately⁵ can provide valuable feedback to learners and instructors. The most skilled and highly trained SPs can give feedback unaided; those at lower levels can give feedback in conjunction with faculty.¹² The quality of SP feedback should be monitored periodically using a checklist such as the Maastricht Assessment of Simulated Patients (MaSP).¹³ After reflection and synthesis following an SP experience, learners may finish the cycle by revisiting the simulated setting, where SPs can reliably re-create their roles, providing learners with an opportunity to apply new approaches to old challenges.

Educators also employ SPs in other teaching roles. Genitourinary Teaching Associates (GUTAs) are laypersons who train learners to perform breast, pelvic and rectal examinations, using plastic models and their own bodies to demonstrate the necessary skills. Similarly, SP physical examination (PE) instructors, trained by expert faculty, are able to teach and assess PE skills effectively according to uniform guidelines, allowing students to demonstrate PE maneuvers on the instructors and to receive immediate instruction and feedback.^{14,15}

The versatility of SPs enables their use as a powerful teaching method in a variety of roles and settings. SPs can give one-on-one feedback in intimate settings such as the examining room after an encounter with an individual learner. At the other end of the continuum, educators can use SPs in a large lecture hall to model interviewing, physical examination, and communication techniques. However, the small group setting is the most common venue for the use of SPs in teaching. A typical example is a “difficult interview” training exercise (e.g., giving bad news or disclosing a medical error). The small group often consists of 6-8 learners with one or two instructors. One learner interacts with the patient; the other learners serve as consultant-observers. The mentors create a safe, non-judgmental learning climate, encouraging learners to experiment with different approaches. The interviewer can call “time out” at any time

and ask peers or mentors for ideas about how to proceed. The mentors may also call “time out” to give the interviewer assistance and feedback, enlisting the other learners and the SP to contribute to this effort. In effect, the small group setting functions as a clinical skills laboratory with opportunities for experimentation and multiple sources of feedback. The SP plays a unique role in the laboratory because only the SP is able to provide feedback from the perspective of the patient. Such feedback offers learners a window, often inaccessible in real practice, to crucial aspects of their performance: the patient’s reactions to their mannerisms, their ability to communicate about delicate subjects, and their techniques for establishing trust. In addition to using SP feedback, mentors can enhance learning in the small group setting by using such approaches as 1) “instant rewind” in which the interviewer asks the learner and SP to replay an interaction for the purpose of experimenting with different approaches; and 2) “tag teaming” in which the mentor substitutes other learners for the lead interviewer so they can work with the SP to test their own approaches.

While first implemented in medical student education, SPs are being used increasingly at all levels of medical education, including programs that assess the clinical skills of entering residents,^{16,17} teach and assess residents' communication and interpersonal skills,^{18,19} and provide hospital staff and practicing clinicians with a safe setting in which to practice how to disclose adverse events and deal with disruptive patients. In addition, other health professions (e.g., physical therapy, physician assistant programs, nursing, dentistry, pharmacy, and veterinary medicine) use SPs for teaching their students. Interprofessional education programs use SPs for team exercises to teach multiple disciplines ways of working together with members of other professions. For example, by portraying a family member or colleague, an SP can present an additional communication challenge for the interprofessional team, increase the fidelity and complexity of the task, and provide unique opportunities for patient-centered feedback. Some SP exercises add mannequins to simulate a medical crisis or other event that requires an interprofessional response.

Testing with Standardized Patients

Standardized patients provide the opportunity to observe and assess learners and clinicians as they respond to complex patient-care challenges, while controlling when,

where, how and what will be assessed. When used for formative evaluation, SPs afford unique opportunities for 1) coaching and debriefing, 2) feedback from the patient's perspective, 3) facilitation of deliberate practice,^{20,21} and 4) development of skills and expertise. The Accreditation Council for Graduate Medical Education (ACGME) recommends the use of SPs for the assessment of resident competencies such as communication and professionalism. From a patient safety perspective, SPs allow educators to ensure that learners have reached a minimal level of competency and skill before they are allowed to work with real patients.

Checklists and rating scales are used to convert behavior during the SP encounter into a number that can be used for scoring. *Checklist* items are statements or questions that can be scored dichotomously as “done” or “not done” – for example, “The learner auscultated the lungs”. *Rating scales* employ a range of response options to indicate the quality of what was done – for example, “How respectful was the examinee?” might be rated on a five-point scale ranging from “extremely respectful” to “not at all respectful”.

Case-specific checklists identify actions essential to a given clinical case and are usually developed by panels of content experts or local faculty.²² Ideally, items should be evidence-based and reflect best-practice guidelines. Raters must be trained to recognize the range of examinee behaviors that merit a score of “done” for a particular action. Observers may complete checklists during the encounter, or the SP can do so immediately after the encounter. Well-trained SPs²³ can complete checklists of 12 to 15 items accurately

Rating scales provide the opportunity for observers to exercise expert judgment and rate the quality of an action. *Global* scale items rate the performance as an integrated whole; for example, “Overall, this performance was: excellent | very good | good | marginal | unsatisfactory”. *Analytic* scale items allow multiple-level rating of specific behaviors; for example, “Student followed up on patient non-verbal cues: frequently | sometimes | rarely | never”. While checklists are usually case-specific, rating scales can be used to score behaviors or skills that are demonstrated across different cases, such as data gathering, communication skills, or professionalism. A variety of

instruments for rating communication and interpersonal skills have been published.^{18,24-28}

Raters must be trained to use checklists and rating scales accurately and consistently. Frame of reference training²⁹ can help ensure that all raters are calibrated and using the scale in the same way. Raters observe and individually score a live or recorded performance such as an SP encounter or chart note, and then together they discuss their ratings and reach a consensus on the observed behaviors corresponding to the checklist items and rating anchors.

Performance on one clinical case is not a good predictor of performance on another case, a phenomenon known as “case specificity”.³⁰ One solution to this conundrum is the Objective Structured Clinical Examination or OSCE,³¹ an exam format that consists of a series or circuit of challenges. Within an OSCE each test is called a “station”; learners start at different points in the circuit and encounter one station after another until the OSCE is complete. A larger number of stations allows for better sampling of the domain to be assessed, thus improving the reliability and validity of the exam. As a general rule, adding more stations with one rater per station improves the reliability and validity of an exam more than increasing the number of raters per station.^{7,9}

The duration of an OSCE station can range from 5 to 30 minutes or longer, depending on the purpose of the exam. Ten to 20 minutes are usually sufficient for a focused history and physical exam.³² Shorter stations allow the testing of discrete skills such as eliciting reflexes; longer stations can be used for the assessment of complex tasks in a realistic context – for example, counseling a patient reluctant to undergo colorectal screening.

The unit of analysis in an OSCE is the station or case, not the checklist item, since items within a case are mutually dependent - for example: whether a resident examines the heart depends on whether she elicited a history of chest pain. Checklist or scale items should be aggregated to create a station score. Ratings of skills that are common to several cases can be averaged across cases to obtain an exam-level score for that skill. For example, communication and interpersonal skills (CIS) scores show moderate correlations across cases, so it is reasonable to average CIS rating

scale scores across cases to obtain an exam-level score. Formal standard-setting methods can be used to set pass/fail cut scores at the case or exam level. Many of the standard-setting methods originally developed for written tests have been adapted for use with standardized patients.³³

Conducting an OSCE can be daunting. Some schools have full-time SP trainers, paid professional actors who serve as SPs, and a dedicated facility that includes several clinic-type rooms with audio-visual recording capability, affording remote observation and scoring of SP encounters. Commercially available online data-management systems 1) facilitate checklist data capture and reporting and 2) allow both learners and faculty to view and comment on digital recordings of encounters from remote locations. Further, OSCEs can be conducted on a more limited budget by using faculty as trainers and raters, recruiting students, residents or community volunteers as SPs, and exploiting existing clinic space in the evening or on the weekend. Video-recording the encounters is helpful but by no means essential.

Research with SPs

Standardized patients offer a feasible, reliable, and valid way to create made-to-order “patients” on demand for research purposes. SPs, unlike real patients, are readily accessible and available, are not vulnerable to harm from clinical errors in the simulated encounter, and can be video-recorded without disclosing protected health information. Researchers can control the case details and “clone” SPs, providing the means to assess the performance of large numbers of subjects with identical patient cases in a standardized way.

The most common function of SPs in research is for program evaluation - i.e., to measure the effect of an educational intervention at the level of clinical performance in a simulated environment. For example, at George Washington University researchers demonstrated improvement in performance in those students who, after their initial encounter, reflected and visited their “patients” a second time.³⁴ SPs can also be used to probe the real world of clinical practice when unannounced or stealth SPs are sent into real clinical practice situations to assess the skills of clinicians. The clinicians, consented months earlier, do not know which patients are real and which are not.³⁵

SPs can also be used to investigate the workings of clinical processes. For example, Beach et al. determined that students with high baseline patient-centeredness received significantly higher patient satisfaction scores from African American SPs than did students with low patient-centeredness.³⁶ SP encounters have helped elucidate clinical reasoning processes during a hypothesis-driven physical examination,¹⁵ and unannounced SPs are being used to probe contextual decision making among practicing clinicians.³⁷

Patient safety applications of SPs include all of the functions described above – instruction, assessment, and research. Like other simulations, SPs allow clinicians at all levels of training to practice both typical and rare high-risk events in a safe and controlled setting. SPs provide practitioners with the experiences of recognizing and managing rare patient presentations such as bacterial meningitis. SPs provide supervised practice with difficult communication tasks such as full disclosure of adverse events or dealing with a disruptive patient or provider. SP-based performance tests can assess core competencies essential to clinical practice and prepare learners for similar tests that are now part of medical licensure. Finally, SP-based research can explore clinical processes that are especially error prone and can serve as a means for safely piloting new procedures.

Other Creative Uses of SPs

Educators are currently exploring new and creative uses of simulation with standardized patients. These fall into three categories: 1) expanded simulation roles for traditional SPs; 2) simulation roles for non-traditional SPs; 3) hybrid human-mechanical simulation. Educators have expanded SP roles to include simulating family members and standardized families that students interact with over many years of training.³⁸ SPs take on the roles of nurses,³⁸ first responders, and bystanders in mass causality exercises, social workers and chaplains in team training for end-of-life care, attending physicians, and members of faculty search committees. SPs interact with learners remotely through teleconferencing³⁹ and in virtual worlds such as Second Life⁴⁰ and star in video vignettes that enhance lectures and computer-based exams. They appear in screen-based simulations as “virtual patients”, programmed to respond to learners' actions via interactive dialogue with text entry, natural language

processing, and video-clip responses.⁴¹ SP encounters also contribute information to the selection of medical students through multiple mini-interviews or admissions OSCEs.⁴²

Typically, to recruit SPs, programs seek healthy people from their local communities – actors, theater groups, or retired persons are common sources. Some programs have worked with parents and schools to recruit children for pediatrics encounters.⁴³ Health care students can be trained as standardized learners, providing dynamic and compelling faculty development programs to improve and assess teaching skills.⁴⁴ The George Washington University program and others have had extensive experience using senior medical students as standardized patients to train, evaluate, and provide feedback to near peers (first and second year medical students).⁴⁵ Peer feedback has special qualities that are highly valued by the receiver.⁴⁶

Hybrid simulation is an approach that combines two or more types of simulation – for example, having the learner interact with an SP while performing a procedure on a mannequin (deliver a “baby” while interacting with the mother), computer simulation (listen to a “baby’s” heart), or simulated body part (start an IV on a pad attached to an SP). Hybrid simulations challenge the learner to multitask - to perform a procedure skillfully while communicating effectively with the patient, family and colleagues, eliciting the challenges and tensions arising from complex situations and encouraging a patient-centered approach.^{47,48}

Summary

Standardized patients provide a controlled, safe means of simulating live encounters with patients, family, students and colleagues. These simulated encounters can enliven lectures and small group instruction, providing compelling opportunities for experiential learning; enable valid assessments of competencies at all levels of training; and provide highly standardized and controlled patients on demand for research purposes. To network with health professions educators working with standardized patients around the world, see the website of the Association of Standardized Patient Educators <http://www.aspeducators.org>.

References

1. Barrows HS, Abrahamson S. The programmed patient: a technique for appraising student performance in clinical neurology. *J Med Educ* 1964; 39:802-805.
2. Barrows HS. An overview of the uses of standardized patients for teaching and evaluating clinical skills. *Acad Med* 1993; 68:443-451.
3. Macy Initiative in Health Communication Casebook, 2003. Referenced in: Yedidia MJ, Gillespie CC, Kachur E, et al. Effect of communications training on medical student performance. *JAMA* 2003; 290:1157-1165.
4. Schimpfhauser FT, Sultz H, Zinnerstrom KH, et al. Communication cases involving standardized patients for medical student and resident training. Buffalo, New York: The State University of New York at Buffalo School of Medicine and Biomedical Sciences; 2000.
5. Howley L. Focusing feedback on interpersonal skills: a workshop for standardized patients. MedEdPORTAL 2007. Available at: <http://services.aamc.org/jsp/mededportal/retrieveSubmissionDetailById.do?subId=339>.
6. Association of Standardized Patient Educators. Available at: <http://www.aspeducators.org>. Accessed December 20, 2009.
7. van der Vleuten CP, Swanson DB. Assessment of clinical skills with standardized patients: state of the art. *Teach Learn Med* 1990; 2:58-76.
8. Tamblyn RM, Klass DJ, Schnabl GK, et al. The accuracy of standardized patient presentation. *Med Educ* 1991; 25:100-109.
9. Colliver JA, Williams RG. Technical issues: test application. *Acad Med* 1993; 68:454-460.
10. Wallace P. Coaching standardized patients; for use in the assessment of clinical competence. New York City, New York: Springer Publishing Company; 2007.
11. Kolb D. Experiential learning: experience as a source of learning and development. Englewood Cliffs, NJ: Prentice Hall; 1984.
12. Bokken L, Linssen T, Scherpbier A, et al. Feedback by simulated patients in undergraduate medical education: a systematic review of the literature. *Med Educ* 2009; 43:202-210.

13. Wind LA, Van Dalen J, Muijtjens AM, et al. Assessing simulated patients in an educational setting: the MaSP (Maastricht Assessment of Simulated Patients). *Med Educ* 2004; 38:39-44.
14. Yudkowsky R, Downing S, Klamen D, et al. Assessing the head-to-toe physical examinations skills of medical students. *Med Teach* 2004; 26:415-419.
15. Yudkowsky R, Lowenstein T, Riddle J, et al. A hypothesis-driven physical exam for medical students: initial validity evidence. *Med Educ* 2009; 43:729-740.
16. Sachdeva AK, Loiacono LA, Amiel GE, et. Variability in the clinical skills of residents entering training programs in surgery. *Surgery* 1995; 118:300-308.
17. Lypson ML, Frohna JG, Gruppen LD, et al. Assessing residents' competencies at baseline: identifying the gaps. *Acad Med* 2004; 79:564-570.
18. Yudkowsky R, Downing SM, Sandlow LJ. Developing an institution-based assessment of resident communication and interpersonal skills. *Acad Med* 2006; 81:1115-1122.
19. Leiphart J, Blatt B, Greenberg L, et al. Standardized training and evaluation of an ACGME core competency in a neurosurgery resident training program. *AANS Neurosurg* 2008; 17:20-25.
20. Ericsson KA, Krampe RT, Tesch-Römer C. The role of deliberate practice in the acquisition of expert performance. *Psychol Rev* 1993; 100:363-406.
21. Ericsson KA. Deliberate practice and the acquisition and maintenance of expert performance in medicine and related domains. *Acad Med* 2004; 79 (10, Suppl.):S70-S81.
22. Gorter S, Rethans JJ, Scherpbier A, et al. Developing case-specific checklists for standardized-patient-based assessments internal medicine: A review of the literature. *Acad Med* 2000; 75:1130-1137.
23. Vu NV, Marcy MM, Colliver JA, et al. Standardized (simulated) patients' accuracy in recording clinical performance check-list items. *Med Educ* 1992; 26:99-104.
24. Stillman P, Brown D, Redfield D, et al. Construct validation of the Arizona clinical interview rating scale. *Educ Psychol Meas* 1977; 77:1031-1038.
25. Makoul G. The SEGUE Framework for teaching and assessing communication skills. *Patient Educ Couns* 2001; 45:23-34.

26. Kurtz SM, Silverman JD, Benson J, et al. Marrying content and process in clinical method teaching: enhancing the Calgary-Cambridge Guides. *Acad Med* 2003; 78:802-809.
27. Accreditation Council for Graduate Medical Education: Outcome Project. Available at: <http://www.acgme.org>. Accessed December 20, 2009.
28. Iramaneerat C, Myford CM, Yudkowsky R, et al. Evaluating the effectiveness of rating instruments for a communication skills assessment of medical residents. *Adv Health Sci Educ Theory Pract* 2009; 14:575-594.
29. Bernardin HJ, Buckley MR. Strategies in rater training. *Acad Manage Rev* 1981; 6:205-212.
30. Elstein AS, Shuman LS, Sprafka SA. Medical problem solving: an analysis of clinical reasoning. Cambridge, Massachusetts: Harvard University Press; 1978.
31. Harden R, Stevenson M, Downie W, et al. Assessment of clinical competence using objective structured examinations. *Br Med J* 1975; 1:447-451.
32. Petrusa, E. Clinical performance assessments. In: Norman GR, Van der Vleuten CPM, Newble DI, eds. International handbook of research in medical education. Dordrecht, The Netherlands: Kluwer Academic Publishers; 2002: 647-672.
33. Downing S, Tekian A, Yudkowsky, R. Procedures for establishing defensible absolute passing scores on performance examinations in health professions education. *Teach Learn Med* 2006; 18:50-57.
34. Blatt B, Plack M, Maring J, et al. Acting on reflection: the effect of reflection on students' clinical performance on a standardized patient examination. *J Gen Intern Med* 2007; 22:49-54.
35. Rethans JJ, Gorter S, Bokken L, et al. Unannounced standardized patients in real practice: a systematic literature review. *Med Educ* 2007; 41:537-549.
36. Beach MC, Rosner M, Cooper LA, et al. Can patient-centered attitudes reduce racial and ethnic disparities in care? *Acad Med* 2007; 82:193-198.
37. Weiner SJ, Schwartz A, Weaver FA, et al. Contextual errors lead to avoidable cost: a multi-site unannounced standardized patient trial. Presented at the Society for Medical Decision Making Annual Meeting, October 2009, Hollywood CA.
38. Clay MC, Lane H, Willis SE, et al. Using a standardized family to teach clinical skills to medical students. *Teach Learn Med* 2000; 12:145-149.

39. Berg BW, Alverson D, McCarty T, et al. Standardized patient interviewing with remote interactive technologies. *J Telemed Telecare* 2007; 13 (3, Suppl.): S14-S17.
40. Stapleton GR. Using virtual environments to improve communication skills for healthcare professionals. Presented at the Distance Teaching and Learning Annual Meeting, August 2009, Madison, WI.
41. Courteille O, Bergin R, Stockeld D, et al. The use of a virtual patient case in an OSCE-based exam – a pilot study. *Med Teach* 2008; 30:e66–e76.
42. Eva KW, Rosenfeld J, Reiter HI, et al. An admissions OSCE: the multiple mini-interview. *Med Educ* 2004; 38:314-326.
43. Lane JL, Ziv A, Boulet JR. A pediatric clinical skills assessment using children as standardized patients. *Arch Pediatr Adolesc Med* 1999; 153:637-644.
44. Gelula M, Yudkowsky R. Using standardized students in faculty development workshops to improve clinical teaching skills. *Med Educ* 2003; 37:621-629.
45. Blatt B, Confessore S, Kallenberg G, et al. Verbal interaction analysis: viewing feedback through a different lens. *Teach Learn Med* 2008; 20:329-333.
46. Lockspeiser TM, O'Sullivan P, Teherani A, et al. Understanding the experience of being taught by peers: the value of social and cognitive congruence. *Adv Health Sci Educ Theory Pract* 2008; 13:361-372.
47. Kneebone RL, Kidd J, Nestel D, et al. Blurring the boundaries: scenario-based simulation in a clinical setting. *Med Educ* 2005; 39:580-587.
48. LeBlanc VR, Tabak D, Kneebone R, et al. Psychometric properties of an integrated assessment of technical and communication skills. *Am J Surg* 2009; 197:96-101.

Authors Notes

Portions of this chapter were adapted with permission from R Yudkowsky: Performance Tests, in *Assessment in Health Professions Education* by Steven Downing and Rachel Yudkowsky (eds). Routledge 2009.

About the Authors

Rachel Yudkowsky, MD, MHPE is Director of the Dr. Allan L. and Mary L. Graham Clinical Performance Center at University of Illinois College of Medicine at Chicago and Associate Director of Faculty Development. She holds an appointment as Associate Professor in the Department of Medical Education. Her areas of research interest include performance assessment using SPs and other simulations and setting passing standards for performance exams, and she is the recipient of research grant awards from the National Board of Medical Examiners' Stemmler Fund and from the Agency for Healthcare Research and Quality. She serves on the Editorial Board of *Simulation in Healthcare*, the official Journal of the Society for Simulation in Healthcare and on the Grants and Research Committee of the Association of Standardized Patient Educators.

Benjamin Blatt, MD is the Medical Director of the CLASS Clinical Skills Center and Office of Interdisciplinary Medical Education at The George Washington University School of Medicine and Health Sciences. He holds an appointment as Associate Professor of Medicine. His reputation for excellence in medical education has been recognized internationally. He recently was asked by the Chinese Medical Doctor's Association to develop a train-the-trainers program in doctor-patient communication and in teaching skills for a select group of Chinese health care professionals, who would then serve as trainers for practicing physicians throughout China. His most recent work concentrates on understanding and applying principles of adult education as students transition from the classroom to the clinical setting.

Designing, Developing and Implementing Branched-Narrative Virtual Patients for Medical Education, Training and Assessment: A Guide for Authors of Virtual Patients

James B. McGee

Introduction

This guide is for healthcare educators developing or considering developing branched-narrative virtual patient simulations for medical education, training and assessment. In a virtual patient computer simulation the learner, playing the part of a healthcare provider, interacts with an on-screen patient to obtain a history, conduct a physical exam, and make diagnostic and therapeutic decisions.¹ A “branched-narrative” virtual patient (VP) is one in which the virtual patient experience progresses as a story. The story changes as the learner makes critical decisions, and those decisions have direct consequences on the patient’s outcome.

The success of an educational initiative using a virtual patient, whether for clinical correlation in a

medical student basic science course or to decrease medication errors as part of a multidisciplinary training program of a hospital system, hinges on a few key factors: 1) reliable, scalable and easy to use technology; 2) adoption by teachers; 3) perception of value by learners; and, most importantly, 4) a high-quality learning experience. This guide focuses on the last element, specifically, how to design, develop and implement virtual patients that effectively meet your learning goals. The recommendations that follow are based on literature-supported educational theories and adult learning and eLearning concepts as well as the experience of the author.

The following terms are used in this guide:

virtual patient (VP): a computer program that simulates real-life clinical scenarios in which the learner acts as a healthcare provider obtaining a history and physical exam and making diagnostic and therapeutic decisions

branched narrative: a virtual patient design that affords multiple narrative paths with more than one outcome

node: a step along a branched narrative story, typically represented by a single screen or web page; the learner progresses from one node to the next based on his/her decisions

student, learner: the person(s) using a virtual patient for education or assessment

author: the educator who conceives and principally creates a VP

Key educational characteristics of virtual patients

Virtual patients possess unique characteristics making them valuable learning tools for education in the healthcare professions. Simulations in general have the ability to engage the learner in repetitive and deliberate practice in a safe and reproducible environment with personalized expert feedback.^{2,3} Patient simulations also allow curriculum administrators to fill gaps in clinical exposure and introduce learners to unusual and rare conditions.⁴ Virtual patients offer some practical and educational advantages when compared to other popular simulation technologies such as mannequin-based physical simulators and human actors posing as standardized patients. VPs delivered over the Internet are relatively inexpensive to distribute, maintain and update compared to their human or ersatz counterparts. Since they are story-based, VPs can describe nearly every known disease state and can provide immediate and personalized feedback without requiring co-location of teacher and learner.

Branched-narrative virtual patients offer the ability to teach clinical decision-making skills and observe the consequences of those decisions while receiving adaptive feedback. The decision→consequence relationship is an educationally valuable VP characteristic, particularly well suited for teaching clinical reasoning skills.⁵ For medical student education St. George's University in London has replaced traditional linear problem-based learning paper cases with web-based branched-narrative VPs. Educators there observe “deep learning” and “critical thinking” related to the key decision points in their VP cases.

Despite their educational value, until recently virtual patients were regarded as too expensive and time-consuming for the average educator to use. Larger institutions with the resources to develop their own VP systems report costs exceeding \$20,000 per case.⁶ The recent availability of easy to use web-based authoring applications has decreased development time ten-fold at the University of Pittsburgh (<http://vpSim.pitt.edu>). Release of virtual patient technical specifications by the MedBiquitous organization in 2010 will allow sharing and repurposing of existing VP cases, further bringing down the time and cost of introducing VPs into a curriculum.⁷

Anatomy of a branched-narrative virtual patient

In its most basic form, a branched-narrative virtual patient contains the following components:

Basic Branched-Narrative Virtual Patient

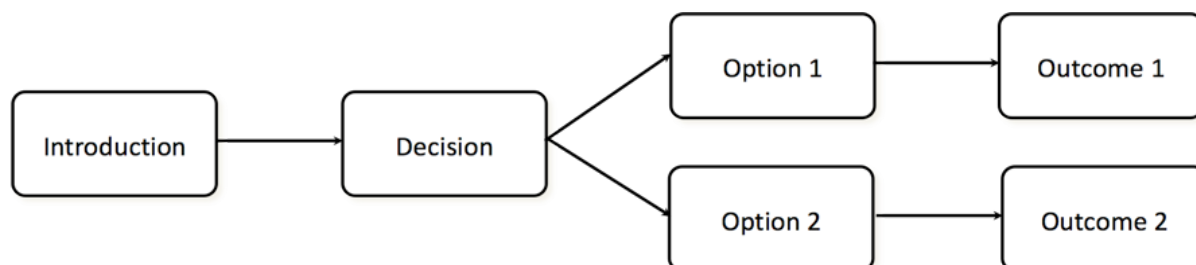

Using this model, a VP author can develop an interactive experience with multiple choices and their associated outcomes and feedback. Often a case begins with an introduction to the patient and a clinical scenario followed by choices to collect data, make a diagnosis and initiate therapy. The results of the learner’s decisions are reflected as the case unfolds in the form of clinical findings, diagnostic test results and improvement or decline in the VP’s clinical status.

Creating a Virtual Patient Simulation

The development process to create a virtual patient case can be categorized into three phases, 1) preparation, 2) design and development, and 3) implementation.

Preparation	Design and Development	Implementation
<ul style="list-style-type: none"> • list learning outcomes • define the audience • assess environmental factors • perform due diligence 	<ul style="list-style-type: none"> • select pedagogic model • tell a good story • set rules and expectations • define the critical path • add branches aligned with learning outcomes • complete narrative and clinical data • add feedback • add multimedia • test the case with learners • validate the case 	<ul style="list-style-type: none"> • create motivation • distribute the case • evaluate the case • maintain the content • report performance

Phase I – Preparation

List learning outcomes

All effective learning programs begin with a clear definition of the intended outcomes or “learning objectives.” While the tendency can be to begin with the narrative for a new virtual patient, explicitly listing learning outcomes at the outset will pay dividends throughout the development and implementation process. A list of learning outcomes is critical to focusing work and communicating with collaborators and other educators who may use the case.

When developing learning outcomes, ask questions such as: “What educational problem am I solving? What behaviors need to change? What skills are being taught? How will the learner be different after he or she completes this virtual patient?”

Well-written learning outcomes are explicit, action-oriented and measurable. A learning objective such as “understand nosocomial infections” is less effective than stating an outcome that is measurable (e.g., “decrease nosocomial infections in the ICU by 30%”). The most effective learning outcomes are clear and concise and can be validated by objective measures.⁸

Define the audience

Identification of a specific audience for a virtual patient aids greatly when defining content, formulating clinical decision-making questions, and developing quizzes and summative assessments. The audience can be chosen in multiple ways:

1. level of training – medical student, resident, practicing physician enrolled in a CME course
2. healthcare discipline – medicine, pharmacy, nursing, dentistry
3. geographic – a single school, within a hospital network, international
4. on-site versus distance learning
5. synchronous (lesson and communication are live) versus asynchronous

New authors often try to create virtual patients that can be applied across various disciplines and at many levels of training. By identifying a specific audience at the

start of planning, later content decisions are more easily resolved. Subsequently you will be able to consider whether your VP can be used with other audiences.

Assess the environmental factors

The characteristics of the environment where learners interact with the VP affect early decisions regarding design and content.

What technology is available to your learners?

Technology factors may play a role in the design and scope of your virtual patient. What computer hardware/software and network/Internet access are required? Knowledge of computer hardware, operating systems, web browser software (including plug-ins), and web access speed is mandatory. The selection of VP authoring and playback software tools should be based on anticipated student capabilities. Ideally, the technical aspects will be tested before development begins.

Requirements for the student

At what juncture in the curriculum will the VP be used? How much time is required for the student to complete the VP case? Is the VP case an optional, extracurricular exercise or a mandated assignment for everyone in your intended audience? Considering the time and resources required for creating a virtual patient, it is best to incorporate VPs into the required components of the curriculum. To this end, VPs should be integrated into the curriculum so that time is scheduled for the learner to complete a virtual patient and perform any external work related to the case's learning objectives.

Requirements for the author

In our experience, authors expend much energy and enthusiasm at the beginning of the VP authoring process. Unfortunately, the final editing and evaluation do not typically enjoy as much attention. "Getting it done" is a frequent problem for authors in many educational programs. The asynchronous nature of most virtual patients may make the completion of case development more common. As opposed to a lecture with a defined time and place, developing VPs is easier to postpone and delay with comparatively less associated public scrutiny. This is especially true for VPs created

as learning options in a curriculum. Thus, as mentioned above, we do not recommend the development of VPs as supplemental learning activities.

Organizational barriers of time, money, and politics

Another preparatory step involves assessing potential organizational barriers. The most prominent are related to 1) time, 2) money, and 3) politics. Most authors are troubled by not having enough of the first two and having to deal with too much of the third.

An assessment of the cost of developing a VP can be made by adding the following: a) startup costs such as software licenses, content licenses, computer hardware, and networking resources, b) maintenance costs of the software and network resources for the perceived duration of the program, and c) costs of personnel time.

Even if the content experts and educators are “donating” their time (often by working at night and on weekends), estimating the true costs is essential when calculating the “value” of your virtual patient.

Broad participation and buy-in by the primary stakeholders in any new program utilizing VPs can generate enthusiasm and smooth the implementation process. An author may perceive himself/herself as the owner of a VP, but the students, expert consultants, facilitators, reviewers, and administrators are also invested to some degree. Giving key stakeholders an opportunity to participate in establishing learning goals for the VP, developing content, and reviewing the product can lower barriers and manage the inevitable changes needed after initial deployment of any new educational program.

Perform due diligence

Is there already an available VP that meets your learning objectives? While virtual patient simulation is a relatively new educational tool, as of January 2010 there are numerous virtual patients in the Association of American Medical Colleges' MedEdPortal database (www.aamc.org/mededportal). Another 350 cases are anticipated from the eViP consortium (www.virtualpatients.eu) in the summer of 2010. The cases in these two databases will also be in the MedBiquitous VP standard (www.medbiq.org) enabling reuse and repurposing by standard-compliant authoring

systems. A recent review of the literature by Cook and Triola compiles and analyzes research regarding virtual patients.⁵ A literature search of PubMed (www.pubmed.gov) revealed 152 matches to the term “virtual patient.” Authors should take advantage of these resources when planning and developing VPs.

Phase II – Design and Development

Select a pedagogical model

Branched-narrative virtual patients can employ various pedagogical models for learner-teacher interaction. An author should consider which of these models best fits his or her local curriculum and goals.

Experience from various institutions has shown success with a variety of designs. Small groups of three or four students working together are often more effective than a student solving a case independently.⁹ Asynchronous communication between students via email or a discussion board is generally more convenient than live interaction but the intermittent nature of learning can be a detraction.

Pedagogic Models for Virtual Patients	
Self-directed learning	Freestanding case accessed by individual learners and completed with limited interaction with the case author, educators or experts
Problem-based learning	Small group learning with a facilitator where the student access and engage as a group with the VP case
Distance learning	Learner independently accesses an online VP case but has remote synchronous (chat) or asynchronous (discussion board/email) engagement with the expert/author
Sequenced or blended learning	The learner engages with a VP in conjunction with supportive didactic instruction, small group discussion, or other simulation exercises
Assessment	Learner is assigned a VP for formative or summative assessment of skills

Student needs for seeking and receiving assistance in making a diagnosis or solving a clinical problem should be considered in designing a VP case. In a live case-based instructional setting the instructor can adapt his/her teaching based on the student’s progress (or lack of). In contrast, with a self-directed, asynchronous VP case all the didactic materials and assistance mechanisms must be incorporated beforehand.

Alternatively, an author can direct students to external sources, but this is inherently unpredictable and typically less acceptable to students.

Nine steps for efficient and effective VP design and development

First, tell a good story

The educational value of a virtual patient relies heavily on the power of the narrative. Learners respond to compelling, engaging stories.^{10,11} Narrative-style VPs have been shown to be superior to the ‘problem-solving’ style for teaching communication skills, and rich-narrative PBL cases have resulted in positive perceptions of learning.^{12,13} Medical professionals rely on their clinical experience (past stories) to recall effective strategies that can be applied to newly encountered related problems. Memorable characters, unique settings, unexpected events, and clever twists in the plot all add to the level of learner engagement and retention.^{14,15}

Authors should write a short narrative before beginning the design process for a VP. Using a real-life patient encounter is usually easier and more accurate than inventing the case. However, to adequately engage the learner and meet all desired learning objectives, embellishing the case is both necessary and recommended.

A story should always have a beginning, middle, and an end.

- a. Beginning - set the scene, develop the characters, set up the ground rules
- b. Middle - develop the “conflict” that relates to the clinical problem at hand; usually this is the patient’s medical complaints and/or problems
- c. End - resolve the conflict by revealing the diagnosis, ideal therapy, and clinical outcome to the learner.

Set the rules and expectations

Explain to the learner what role he/she is playing (doctor, nurse, pharmacist, etc.), how long the case will take, what the learner is expected to do, and how performance will be assessed.

Define the critical path

The critical path is the sequence of events (nodes) that define an ideal storyline where the learner makes all the right decisions from beginning to end, and the patient has

the best possible clinical outcome.¹⁶ Flip charts or a whiteboard may be used to brainstorm and map the case at this early stage. Many VP developers start the diagram with a beginning node in the upper left corner of a whiteboard or computer screen and work downward to the lower right to the ideal outcome or terminal node. A **node** is a step along a branched narrative story, typically represented by a single screen or web page; the learner progresses from one node to the next based on decisions

Add branches at critical clinical decision points aligned to learning outcomes

Branches in the case take place at the primary decision-making nodes and should correlate with the case’s learning objectives. These nodes are challenge points where learning tension develops. If sufficiently difficult, a student should pause at a branching node and think critically and deeply before making a decision. The effectiveness of a branched-narrative virtual patient is highly dependent on the appropriateness of these branched decision points.

Node Maps

Critical Path

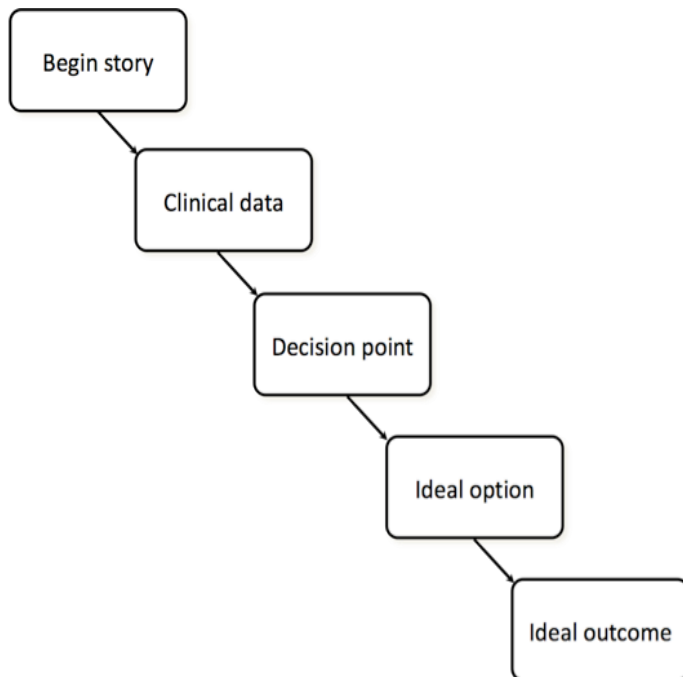

Branched Path

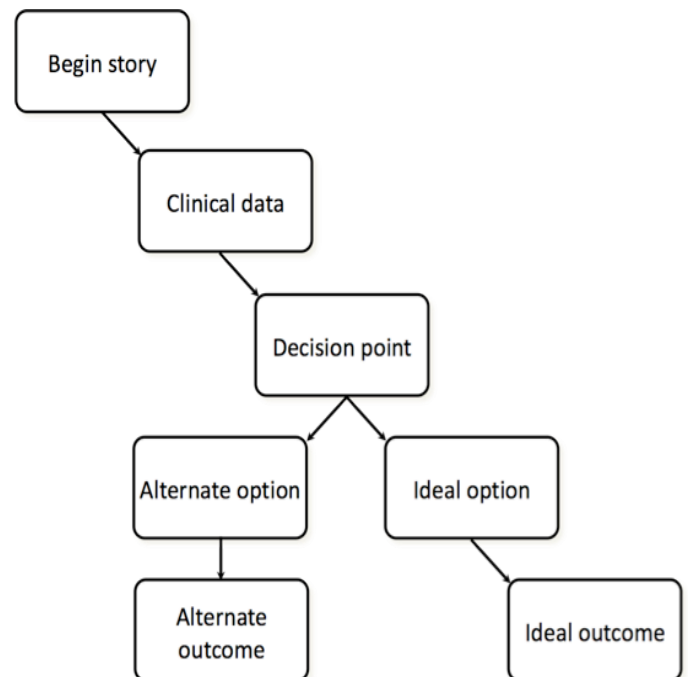

Based on experience, critical decision nodes often do not challenge the learner to the point of stimulating deep thinking. Authors should test how learners respond at these branch points using the “think aloud” technique.¹⁷ Complete the narrative and clinical data

Once the various nodes, paths and outcomes are laid out, fill in the necessary story and clinical data on each node with text and multimedia. Nodes are added as needed to complete the narrative and provide feedback and alternative paths as selected by the learner. Attention should be paid to format and quantity of text and multimedia on each page. More than one media element (image, video, animation) can be distracting and contribute to cognitive overload. Use what graphic designers refer to as “white space” to provide the learner an opportunity to absorb new data and to process his/her thoughts.

Add feedback

There are many ways to provide feedback to the student during and at the end of a virtual patient experience.

- a. *Author comments based on branching.* As a student makes selections at branch points, subsequent nodes can provide author feedback regarding the clinical decisions made. Comments can be either qualitative (e.g., “I don’t think it is a good idea to give your patient epinephrine now...”) or quantitative (e.g., “that dose of epinephrine increased your patient’s blood pressure to 160/98...”).
- b. *Patient and author responses to questions.* Some VP authoring programs allow more than one question on a single node (e.g., interviewing a patient, ordering diagnostic tests, and presenting multiple choice knowledge questions). A response from either the patient (“that hurts”) or author (“that therapy has greater risk than alternatives”) tells the student how he or she is progressing.
- c. *Counters.* Numerical values can follow decisions made by the learner and are reported either on-screen during the case, periodically at key points, or at the end of the VP in summative terms. Authors can designate that these results be reported as performance scores (in absolute or relative form) and dollar values for diagnostic and therapeutic choices. Advisory comments may be triggered that inform the learner regarding guidelines, policies, and best practices.

- d. *Clinical outcomes.* The most powerful feedback can be the virtual patient's clinical condition. The learner's choices and performance are reflected in the virtual patient's clinical status that either improves or declines. At key points, the author can provide feedback regarding the patient's expected clinical status and, if the author wishes, allow the learner to back up and try again.
- e. *Facilitator comments and guidance.* Cases that are conducted with a live small group and facilitator benefit from his or her guiding comments. If a facilitator has content expertise, then his/her teaching can be adapted on-the-fly to the performance of students. This impromptu approach takes less time to develop since it does not require the author to anticipate and write a comment about every decision. However, in contrast to self-directed learning, a live teacher with a small group requires physical space for instruction as well as an investment of instructional time from the instructor.
- f. *Group discussion.* Students benefit from discussing the case with their peers and making decisions as a team. This interaction may take place live or via an online chat. Preferably these sessions occur synchronously since asynchronous communication via email or discussion board may be complicated if students progress through the case at different rates. Electronic approaches provide a transcript of the thinking behind the decisions and can be used by the author to better understand students' learning process.
- g. *External resources.* An author may direct a student to specific external resources such as journal articles, textbooks, or decision support tools.

Adaptive learning with branched-narrative VPs

Branched narrative VPs enable authors to develop learning experiences that can change based on the learner's performance during a case. Adaptive choices can be positioned at the beginning of a case by asking the learner what level of training he or she has and then branching down paths of varying complexity. Or, the case can include multiple-choice questions that assess the learner's comprehension and then progresses to either a higher level or a remediation path.

Adaptive Feedback

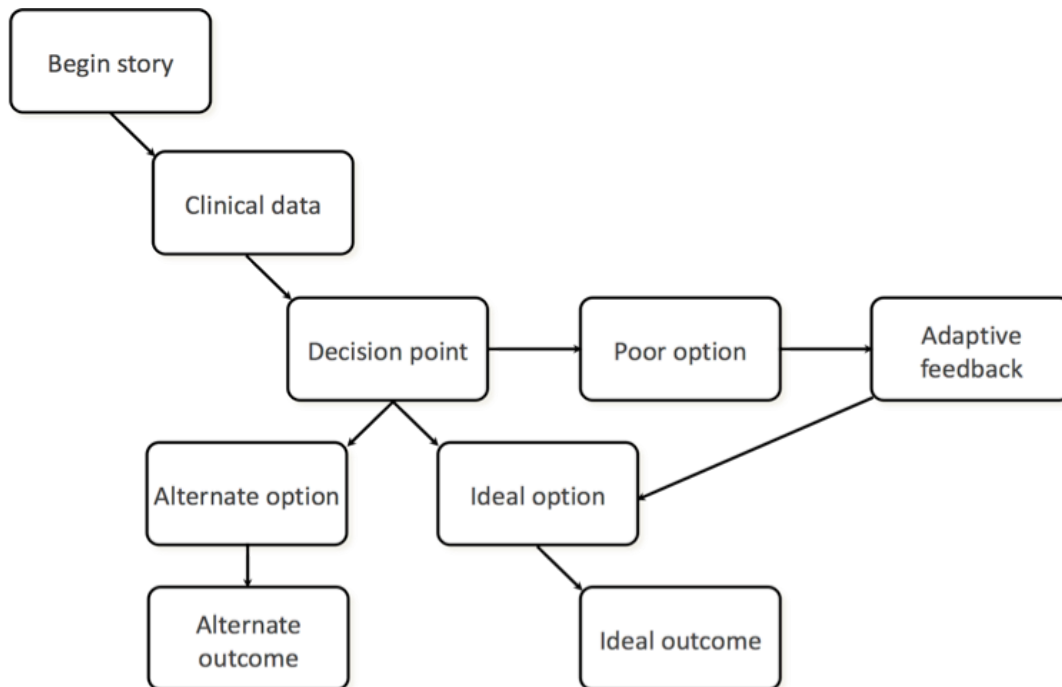

Add multimedia

Images, audio, video and animation can add to the educational and perceived quality of a VP.¹³ As noted, VPs rely on the power of an engaging narrative to suspend disbelief and create an immersive simulation experience. Visual and auditory components, when done well, add to the “suspension of disbelief” but have not been shown consistently to increase the educational value of the VP experience. Further, video and audio elements can create cognitive overload and detract from learning when done to excess.

Static images and video can be helpful in setting the scene and establishing a mental image of characters in the story. Multimedia is especially valuable when used to demonstrate specific historical, physical and diagnostic findings.

Locating media for a virtual patient presents a challenge for many authors. While searching using online resources like Google Images (<http://images.google.com>) is fast and convenient, nearly all of these images are copyright protected and cannot be used in your virtual patient without permission. Copyright laws, fair use guidelines, and patient confidentiality need to be taken seriously. A detailed review is beyond the scope of this guide, but the reader may refer to the following for more information:

- Fair-use guidelines: <http://www.copyright.gov/fls/fl102.html>
- Health information privacy: <http://www.hhs.gov/ocr/privacy/>
- Copyright law: <http://www.copyright.gov/>

There are online collections of images and videos that can be shared with authors.

MedEdPortal (www.aamc.org/mededportal) and Health Education Assets Library (www.healcentral.org) are recommended starting places for medical education-related media. General online repositories that offer shareable images and videos based on Creative Commons licensing can be helpful for non-medical images [see Flickr (www.flickr.com) or Picasaweb (picasa.google.com)]. Also, for a small fee the author can obtain edited images from professional resources, where visual material is generally of better quality [Images.MD (www.images.md), Getty Images (www.gettyimages.com)].

More on scores, counters, and rules

Counters in a branched-narrative virtual patient are applied at decision points and associated with metrics such as the cost of a diagnostic test, time required to complete a history, or self-report measures such as a pain scale. Reports to learners and faculty during or at the end of a VP case are the simplest use of scores and counters. A comment from the author should accompany the possible and expected range for each score/counter. Additionally, there can be a discussion in a small group about how the scores relate to clinical decisions and patient outcomes.

Rules that trigger an event or change in the narrative while progressing through the case may be applied to a counter. These alerts can be in response to exceeding a spending limit, or reaching a positive or negative score that is outside a target range. When a rule is triggered, the user jumps to a node where the author can give feedback and/or a change in the patient's condition to reflect this event. The author can direct the user to back up and try again, give remediation, or end the case abruptly.

Test with students

After a satisfactory amount of the case content has been developed and the critical decision branches and their consequences have been created, one or more representative students can be asked to work through the case. Trial students should receive only minimal instructions and prompting. As mentioned above, use the “think aloud” method, where the students describe aloud what they are thinking as they make decisions and the case unfolds. These sessions can be quite revealing.

Validate the case

The case needs to be valid in terms of both content and user experience. A case can seem complete and coherent to the author, but when assessed by another subject matter expert or a member of the anticipated target audience, it may result in unpredictable, undesirable outcomes. Even worse, students may experience frustration or be unable to complete the case. Every possible path, along with its resulting clinical outcomes, scores, and feedback, must be investigated. As mentioned above, testing is essential.

Regardless of an author's level of expertise with a particular topic, involving others in the authoring and reviewing process typically results in a more effective virtual patient learning experience.

Phase III – Implementation

Establish motivation

A sustainable virtual patient curriculum must establish the motivation for learners to engage with and complete virtual patient cases.

Active learning that simulates a clinical encounter and provides dynamic feedback will be more compelling than many other forms of learning. Branched-narrative VPs can be especially motivating at key decision points, with game-like positive and negative reinforcement. The learning experience is even more engaging when the learner is challenged, makes a mistake, and the patient's status declines. Such consequences create a powerful "teaching moment."

The newness and originality of VPs can attract students initially, but interest can wane unless a strong perception of value is established from the first case onward. As outlined above, educational value comes from having a high-quality engaging case that achieves its learning outcomes. To this end, an effective VP should strive to tell a compelling story with valid clinical events that occur in response to the learner's decisions. Authors should refine their cases based on testing prior to release, and from observing students' reactions and performance after implementation.

Distributing VP cases

Virtual patients are either stand-alone software applications, network applications (accessed from an institutional server), or web-based. Stand-alone VPs benefit from not requiring the user to be connected to a network, but updating, version control, and tracking user activity are much easier with web-based applications. Software-as-a-service or “cloud computing” is gaining popularity because it requires only an Internet connection and web browser to both access and author cases and eliminates the need for local technical support and maintenance. Web-based distribution is particularly popular since it makes virtual patients available on-demand from anywhere.

Commonly used methods for distributing web-based VP cases include:

1. Emailing a link to the case. This is a convenient mechanism since most people check email daily. Therefore, the case is unlikely to be missed.
2. Embed a link to the case on an institution’s web page.
3. Direct the learner to a third-party VP application web page. After logging in, the user will see the cases to which he or she has access or has been assigned.
4. Embed a link within a learning management system (LMS). Authentication and identification of the user can be passed directly from the LMS without having to log in again. This will ensure that the users are identified correctly and their progress is tracked and reported back to the LMS.

Large educational programs that use a number of VPs will want to use a VP software application for managing case access and distribution to groups of learners, such as a medical student class or hospital department. Sophisticated tracking and reporting tools become essential when managing dozens of cases for hundreds of medical students or thousands of CME users.

Case meta-data

Meta-data refers to information about a case that is not necessarily included in the case content that the student sees (e.g., the author’s name, institution, date of creation, and date of last update). Keywords, target audience, topics covered, and other indexing terms should be included in the meta-data to permit searching for a

needed case, without having to review the entire story. A case's learning outcomes (objectives), a short case description, and teaching notes will aid potential users in determining if a case will fill an educational need. Authors might also want to include the educational setting (environment) for which the VP was created, how students may access the case, its typical duration, and advice on integration of the case within a curriculum.

Ongoing evaluation

After the release of a VP case authors should seek feedback from both the learners and their teachers, facilitators, and course directors. At a minimum ask if the case was coherent, engaging, and produced a positive learning experience. Were the learning goals met? Did the case seem authentic? Analysis of paths selected by learners and scoring patterns can inform authors about the target audience's performance, areas of weakness, and practice patterns.

Surveys and focus groups can be useful during the post-production refinement of a case. Further, objective analysis can include observations of behavior change and patient outcomes, although these will require formal educational research studies.

Maintenance and growth

A well-constructed and educationally valuable VP case may be used for many years and therefore require updating. VP software applications require version tracking so that as clinical and didactic information is updated, students always access the latest version while administrators can still look back and view older versions and their associated student performance data. A case may be adapted for different learning outcomes and audiences, making version tracking even more critical.

Creating a high-quality VP case is a significant scholarly activity. Consequently, educators should consider submitting the case for peer review by MedEdPortal and sharing its use through the MedBiquitous VP (MVP) data standard (www.medbiq.org). A VP authoring program can facilitate this process by exporting the case using the American National Standards Institute (ANSI)-approved standard (www.ansi.org), which then can be imported into any MVP-compliant VP software application for reuse and repurposing.

Reporting

Reporting learner performance can range from a simple list showing who successfully completed a case to sophisticated decision maps showing how an individual learner's management compares to an expert's path through a case. Typical VP reports show scores, money spent, time spent, and other counter data along with information about what decisions a learner made and where the case ended. Programs with many cases and students will want to export case data using common spreadsheet and database formats. These raw data can then be imported to other software and processed as needed.

Examples of Typical VP Implementations

Virtual patients meet a wide range of educational goals. Some common methods of implementing virtual patients are listed below:

- *Problem Based Learning (PBL) model.* Learners explore the simulation in small groups with a facilitator; navigation is relatively free-form allowing learners to investigate on their own; learners set their own learning goals based on the challenges presented in the case.
- *Self-directed learning model.* Learner works independently with a VP case; feedback is provided using both inline and adaptive techniques; scores, money spent, and other metrics provide performance data; comparison between learner's management and case outcomes to expert's; can loop back to try again.
- *Embedded model.* An interactive VP exercise is embedded in traditional lectures or small group workshops.
- *Case workshops.* Small group sessions with a facilitator; group interacts with the case, stopping to discuss decisions and outcomes; can blend with didactics related to case.
- *Bedside supplement* Trainees are engaged with VPs having similar conditions as their real patients before, during or after bedside rounds; facilitated discussion based on both actual and virtual cases.
- *Blended simulation.* Used in conjunction with mannequin simulators, part-task trainers, or standardized patient actors; narrative can extend from one

simulation technology to another; for example, can combine independent learning using a VP case with a group session using a mannequin, followed by debriefing on both.

- *Assessment model.* Individual use; invisible scores; can receive feedback and quantitative scores at the end; may be used during (formative) or at the end (summative) of an organized curriculum.
- *Continuing [Medical] Education (CE/CME) model.* Independent learners access the VP as-needed based on personal and externally mandated learning goals; access based on their own schedules; completion or competency can be based on scores, case outcome, or time to complete; can include option to try over to achieve a passing score.
- *Training model.* Training materials are delivered in a case-based format and widely distributed; can be managed from one central location including user access control; detailed reporting of performance and completion status.
- *Just-in-time learning.* Timely topics are provided on-demand or triggered by clinical events and decision-support systems.
- *Distance learning.* Web-based VPs can be distributed worldwide and accessed on-demand; adaptive learning provides a platform to deliver customized content to a wide variety of learners with differing levels of expertise.
- *Quality assurance.* Uses cases to assess practice patterns and clinical decision-making behaviors; adaptive learning triggers reinforcement or remediation.

Conclusions

Teaching with cases whether live or simulated comes naturally to both healthcare educators and learners. Newly available virtual patient authoring tools extend these methods to the Internet to efficiently deliver and share case-based learning anywhere and anytime. Now, any motivated educator has the potential to develop his or her own virtual patients with engaging narratives and clinical reasoning challenges in a safe, consistent environment supplemented with adaptive feedback and performance tracking.

Despite technological advances, authoring VPs still requires a few new skills to ensure adoption by learners and positive learning outcomes. Guidance for developing these skills has been presented, including proper preparation, step-by-step design and development, and creative and sustainable ways of implementing VPs in diverse curricular settings.

As more educators take advantage of these new tools and the depth and breadth of VP cases expand, so must the educational research to define and demonstrate when and how best to use VPs. Virtual patients will never completely replace real patients, and the ideal mix of live clinical encounters, traditional learning methods, and simulation will be the subject of future research. The author hopes that learners in all areas of healthcare will sharpen their clinical reasoning skills with well-designed branched-narrative virtual patients. The enhanced clinical competence of practitioners will result in improved clinical care and, most importantly, will produce better *real* patient outcomes.

References

1. Association of American Medical Colleges. Effective use of educational technology in medical education: summary report of the 2006 AAMC Colloquium on Educational Technology. Washington, DC: AAMC; 2007:7.
2. Issenberg SB, McGaghie WC, Petrusa ER, et al. Features and uses of high-fidelity medical simulations that lead to effective learning: a BEME systematic review. *Med Teach* 2005; 27:10-28.
3. van Merriënboer JJG, Clark RE, de Croock MBM. Blueprints for complex learning: the 4C/ID model. *Educ Technol Res Develop* 2002; 50:39-64.
4. Tworek J, Coderre S, Wright B, et al. Virtual patients: ED-2 band-aid or valuable asset in the learning portfolio? *Acad Med* 2010; 85:155-158.
5. Cook DA, Triola MM. Virtual patients: a critical literature review and proposed next steps. *Med Educ* 2009; 43:303-311.
6. Huang G, Reynolds R, Chandler C. Virtual patient simulation at U.S. and Canadian medical schools. *Acad Med* 2007; 82:446-451.

7. MedBiquitous. Virtual patient working group. Available at: http://medbiq.org/working_groups/virtual_patient/index.html. Accessed February 8, 2010.
8. Mager RF. Preparing instructional objectives (2nd ed.). Belmont, CA: Fearon; 1975.
9. Gesundheit N, Brutlag P, Youngblood P, et al. The use of virtual patients to assess the clinical skills and reasoning of medical students: initial insights on student acceptance. *Med Teach* 2009; 31:739-742.
10. Polkinghorne D. Narrative knowing and the human sciences. Albany, NY: State University of New York Press; 1988.
11. Schank RC, Cleary C. Engines for education. Hillsdale, NJ: Lawrence Erlbaum Associates; 1995.
12. Bearman M, Cesnik B, Liddell M. Random comparison of 'virtual patient' models in the context of teaching clinical communication skills. *Med Educ* 2001; 35:824-832.
13. Bizzocchi J, Schell R. Rich-narrative case study for online PBL in medical education. *Acad Med* 2009; 84:1412-1418.
14. Hunter KM. Narrative, literature, and the clinical exercise of practical reason. *J Med Philos* 1996; 21:303-320.
15. Laurillard D. Multimedia and the learner's experience of narrative. *Comput Educ* 1998; 31:229-242.
16. Conradi E, Poulton T, Round J. Teaching decision-making skills through inexpensive virtual scenarios. Proceedings of the 2007 Computers and Advanced Technology in Education Meeting, October 2007, Beijing, China.
17. Lewis CH. Using the "thinking aloud" method in cognitive interface design. Technical Report IBM RC-9265; 1982.

About the Author

James B. McGee, MD is the Assistant Dean for Medical Education Technology and Director of the Laboratory for Educational Technology at The University of Pittsburgh School of Medicine. He holds an appointment as an Associate Professor of Medicine. He has been working in the area of virtual patients for over 15 years. His web-based virtual patient authoring system, vpSim, is being used by educators internationally. He

serves as the Co-Chair of the MedBiquitous Consortium's Virtual Patient Working Group and recently received its Implementer of the Year Award. MedBiquitous is an ANSI-accredited developer of information technology standards for healthcare education and competence assessment.

Virtual Environments

Jennie J. Gallimore, April L. Barnes and Rosalyn P. Scott

Introduction

The concept of Virtual Reality (VR) began in 1956 when Morton Heilig invented “Sensorama[®]”, a single user theater experience to stimulate multiple senses including use of a stereoscopic (3-Dimensional [3D] display), speaker system, smell and motion.¹ Advances in computer technology in the 1960s led Ivan Sutherland, an Associate Professor at Harvard and inventor of Sketchpad[®], the first computer-aided design system, to develop the concept of using an “Ultimate Display” to allow a person to look into a virtual world.

“The ultimate display would, of course, be a room within which the computer can control the existence of matter. A chair displayed in such a room would be good enough to sit in. Handcuffs displayed in such a room would be confining and a bullet displayed in such a room would be fatal. With appropriate programming such a display could literally be the Wonderland into which Alice walked.”²

Sutherland built a stereo head-mounted display attached to a computer and tracked head movement so that the scene changed as the user moved his or her head. The science of VR was born, yet it was not until the late 1980s and 1990s that the general public came to know VR technology and systems. The research and design of flight simulators and advances in computing power transformed concepts into actual systems. Today VR is more commonly called Virtual Environments (VE). The application of VE can be found in the domains of manufacturing, equipment design, war fighter readiness, mine safety, entertainment, cultural training, mission or task planning, architecture or space layout, understanding of 3D structure, training in high stress or dangerous settings, social networking, the exploration of complex data, and improvements in healthcare.

VE is often used to describe a wide variety of computer-based applications and is frequently associated with its immersive, highly visual, 3D characteristics. There is no

universally accepted definition of VE. It has been defined based on the type of technology being used, such as head-mounted displays, stereoscopic capability, input devices, and the number of sensory systems stimulated. The purpose of VE is to create a world in which the stimuli match human sensory and perceptual capabilities to make the experience as real as possible. VE provides users with a sense of immersion in the synthetic world. A VE system should stimulate multiple senses, including the visual, auditory and haptic, and should allow the user to interact in and become part of the environment. In a fully immersive VE the user sees only the created world. At a less advanced level some would label desktop synthetic worlds as VEs experiences.

The Technology

VE hardware adapts rapidly to advances in technology and to market changes, mostly driven by the gaming industry. The essential hardware requirements include a computer with advanced graphics capability, a visual display, tracking systems, and input devices. Haptic and 3D auditory systems are also available but not always included.

Computer

Advances in computer processing speed and memory make it possible to use desktop computers to create VEs. The advent of greater processing power, abundant memory, and sophisticated graphics cards allow for the creation of complex graphic scenes rendered at faster rates to keep up with human perceptual processing. There is a trade-off between the amount of computer power available and the complexity of the VE created. Also, computing power must be updated as software complexity increases over time.

Visual Displays

Visual displays range from desktop computer screens to immersive large walls wrapping around the users.

Table 1. Types of display technology.

Display Type	Description
2-Dimensional (2D) computer monitor or television	Provides 2D (flat) view of a 3D world. All depth cues are provided through monocular coding.
Stereoscopic display with glasses	Uses two images, one to each eye, to create stereoscopic images. Glasses are used to synchronize images sent to the two eyes. Includes 3D television.
Autostereoscopic display with no glasses	Uses different techniques to aim light to each eye such that a stereo image is seen. Glasses are not required. Resolution is lower than stereoscopic displays.
Stereoscopic projection	Provides a separate image to each eye and require glasses. Employed in large immersive environments that surround the user.
Head-mounted display (HMD)	Uses small liquid crystal images placed in front of each eye with a head mount. Can be stereo or non-stereo. There is a trade-off between the HMD field-of-view (FOV) and resolution. ^{3,4}
Holographic display	Creates photographic images with two superimposed pictures of the same object from different reference points. Requires the use of lasers.
Volumetric display	Presents a 3D image with the emission and scattering of light. True 3D images that fill a volume of space. Typically built using rotating mirrors.
Retinal scan display	Draws raster lines (used in Cathode Ray Television [CRT TV]) directly onto the retina. Developed in Japan, this technique is not widely used.

Tracking Systems

Immersion in a VE requires tracking of users to determine their locations in the 3D world. Typically, the head is tracked to allow the user to turn his/her head and look around in the environment, simulating natural head movement to view different areas of the world. The most common types of tracking systems are electromagnetic, acoustic, optical, and inertial.⁵ Electromagnetic systems use magnetic fields with a transmitter and receiver that measure changes in the magnetic fields to detect position and orientation. A disadvantage to this system is interference from other magnetic fields and metals. Acoustic systems use ultrasonic sound waves. The system measures the amount of time for the sound to reach the sensor. This type of tracking system tends to be slow. Optical tracking systems use cameras and mounted optical markers to determine orientation. These systems are fast, but the line of sight between the camera and marker cannot be blocked. Inertial tracking systems utilize accelerometers, gyroscopes, and the laws of inertia. Because of problems with drift,

these systems are often developed as a hybrid technology combining inertial tracking with another technique such as optical or acoustic.

Input Devices

Input devices are a crucial component of VEs and can have a significant effect on human performance. When trying to interact in 3D space, it is necessary to use devices that allow for natural movement within that space. In many cases 2D input technology, (e.g., 2D mouse, keyboard, game controllers) are being used to interact within the VE. The required type of input device depends on the task being performed. Research reporting on advances in computer algorithms to support custom designed 3D input devices with six degrees-of-freedom (DOF) has addressed the issues related to one-handed versus two-handed performance.⁶⁻¹² Six DOF refers to the motion of an object in 3D space that includes 3 DOF in the translation axes (X [horizontal], Y [vertical], and Z [in and out of the display]) and 3 DOF related to rotation axes (object heading, pitch and roll). There is an assortment of 3D input devices on the market, including 3D mouse, gloves or bodysuits used in conjunction with optical trackers, 3D wands, haptic joysticks, and sensor-based devices such as the Nintendo Wii™ game stick controller. Input devices can be created from other apparatus with the use of appropriate sensors. For example, researchers have used treadmills and stair steppers and inserted sensors into doll heads and baseballs.⁹ Creating natural six DOF input devices continues to be an important research area.

Sound

Sound adds realism to a VE when, for example, an input device touches an object in the VE. In the real world, sound provides important spatial location, such as the position of moving emergency vehicles. 3D auditory displays can be used to provide additional information when the visual system is overloaded. Spatial auditory systems use head-tracking and Head Related Transfer Function (HRTF) algorithms that include the physical cues of the listener and the location of the sound.¹³ While generalized HRTF algorithms are often used, the most realistic 3D sound is achieved by customizing the HRTF for each listener.

Haptics

The ability to feel the VE may be critical for some applications. Surgical training and other skills in which visual feedback is limited require users to rely partially on haptic feedback (touch and proprioceptive) to perform tasks.^{14,15} Continued skill practice may transfer to the user creating the same forces during real world application. Whether transfer is positive or negative depends on how realistic the forces are. For example, if the amount of force needed in the VE does not match the real world force, the user may subsequently use inappropriate forces in the real world task. The limited research in the area of haptic input and feedback suggests that additional research and development are critically needed. There are no specific answers as to when haptic feedback is required to achieve specific learning curve differences compared to no feedback. However, theoretically, the ability to simulate valid tactile and proprioceptive feedback should provide more realistic, immersive experiences.

Software

VE requires the creation of 3D models and physical rules of interaction using software. The more sophisticated the VE or the more realistic the environment, the greater the resources (time and cost) required for development. Since VEs are designed for specific applications, there is no generic VE that fits most requirements. Computer graphic experience is important for development. VE software platforms have emerged to support development (e.g., Di-Guy, VegaPrime, Quest3D[®], 3DVIA[™] Virtools[™] and WorldViz[™]). As with VR hardware technology, software solutions may enter the market with such dispatch that support or upgrades are not readily available.

Considerations, Advantages and Disadvantages

The theoretical advantage of a VE is that the created world would be nearly identical to interaction in the real world. Consequently, due to its natural and intuitive feel, users move effortlessly between the real and the created. Although this advantage of realistic natural interaction has not yet been reached, current technology has yielded positive outcomes. Further, a practical advantage of VE is its ability to train or practice when the real world environment is difficult or unsafe. Compared to actual flight experience, aircraft flight simulation is sufficiently realistic that pilots may perform their first real-world landing with passengers on-board. In healthcare, simulators and

VEs fill the void when real patient practice opportunities for novices are limited or unethical. For example, healthcare teams may perform in a disaster setting with only simulated or virtual learning opportunities beforehand.

Currently, a disadvantage of VEs is the possibility of cybersickness. Cybersickness is similar to simulator sickness and motion sickness. Symptoms include headaches, eyestrain, pallor, sweating, dryness of the mouth, disorientation, nausea, vomiting, ataxia, and fatigue. Research comparing cybersickness to simulator, motion, and space sickness indicates that the symptom profiles are slightly different. The symptom profile for cybersickness is primarily Disorientation symptoms (D) followed by Nausea (N), then Ocularmotor disturbances (O) [D>N>O]. The simulator sickness profile is (O>N>D), space sickness (O>D>N), and sea/air sickness (N>D>O).¹⁶

The impact of aftereffects is another important issue with the use of VEs. According to Welch,¹⁷ five perceptual or sensory adaptation issues are:

- Intersensory conflict
- Distortions of depth and distance
- Distortions of size and form
- Loss of stability of the visual field
- Sensory “disarrangement.”

After effects are caused by conflicts in the sensory systems (seeing motion but not moving), viewpoint differences in created worlds, feedback delays, and changes in sensory feedback over time. These effects must be considered when designing a VE. Aftereffects from flight simulators have led to pilots having a mandatory waiting period before actual flight. In addition, research should investigate the aftereffects and their implications on performing surgical procedures immediately following a fully immersive experience. There is still considerable research required to develop realistic VE that provide positive experiences and reduce health and adaptation issues.

Applications to Clinical Practice

VEs and 3D technology have been applied to clinical practice in multiple domains. In healthcare, surgery, mental health, and rehabilitation are among the specialties that

have incorporated VEs into strategies for training professionals in diagnosis and treatment. VE applications for clinical practice can be placed in two categories: 1) 3D visualizations of a partial or complete virtual human or 2) VE for user interaction.¹⁸

A 3D representation of an organ or organ system (e.g., cardiovascular or neuromuscular) can be used for education focused on clinical practice (i.e., diagnosis and treatment). Further, psychologists and psychiatrists use VEs to provide a human-computer interaction with the patient as an active participant in a 3D world.¹⁸ VEs developed for social networks, such as Linden Lab's[®] SecondLife[®], are employed as a tool for education and support. Combinations of these modalities with varying degrees of fidelity can be used for context-driven education and training for clinical practice. Below we describe examples of applications.

3D Models/Visualizations

3D virtual models of anatomical structures are being used more widely as visualization techniques are becoming more sophisticated. The creation of complex 3D models requires high-resolution data sets acquired from time-intensive and costly scanning techniques such as Magnetic Resonance Imaging (MRI) or Computerized Tomography (CT). Researchers use such non-invasive imaging techniques to develop models for both clinical and educational purposes. The National Library of Medicine's Visible Human Project[®], which began in 1986, is the most comprehensive data set for use in 3D modeling.

Researchers are using 3D modeling and visualization to develop a novel process for the diagnosis of Diffuse Coronary Artery Disease (DCAD). Clinical investigators have adopted Computerized Tomography Angiography (CTA) as a non-invasive technique for imaging the coronary arteries and extracting morphometric data.¹⁹ Quantitative measurements, such as the length, diameter and volume of vessels, are derived from the raw image data. The relationship between vessel length and volume, a measure of how much blood flow the vasculature allows, is an indicator of a diseased state. Simulating the blood flow within the extracted geometry can provide further insight into the flow characteristics of the geometric configuration of the vasculature.²⁰ Similarly, certain configurations of branching angles can cause disease. Hence, the 3D modeling system enhances diagnostic decision-making by computing the angles

between the branches of all vessel bifurcations.²¹ Where there is adequate software support, 3D models and visualizations can be generated for large-scale vascular data sets utilizing extracted geometric measurements.²² Users can study the vascular structure in detail to ensure a correct diagnosis, and areas of likely disease within the vasculature can be highlighted. (See Figure 1.) Clinicians are provided with an enduring and accurate mental map of an organ system when they immerse themselves within high-resolution images and travel through the vasculature. Consequently, the clinician is better able to make management decisions in the diagnosis and treatment of cardiovascular disease.

Figure 1. Visualization of a coronary artery as extracted by the algorithm.

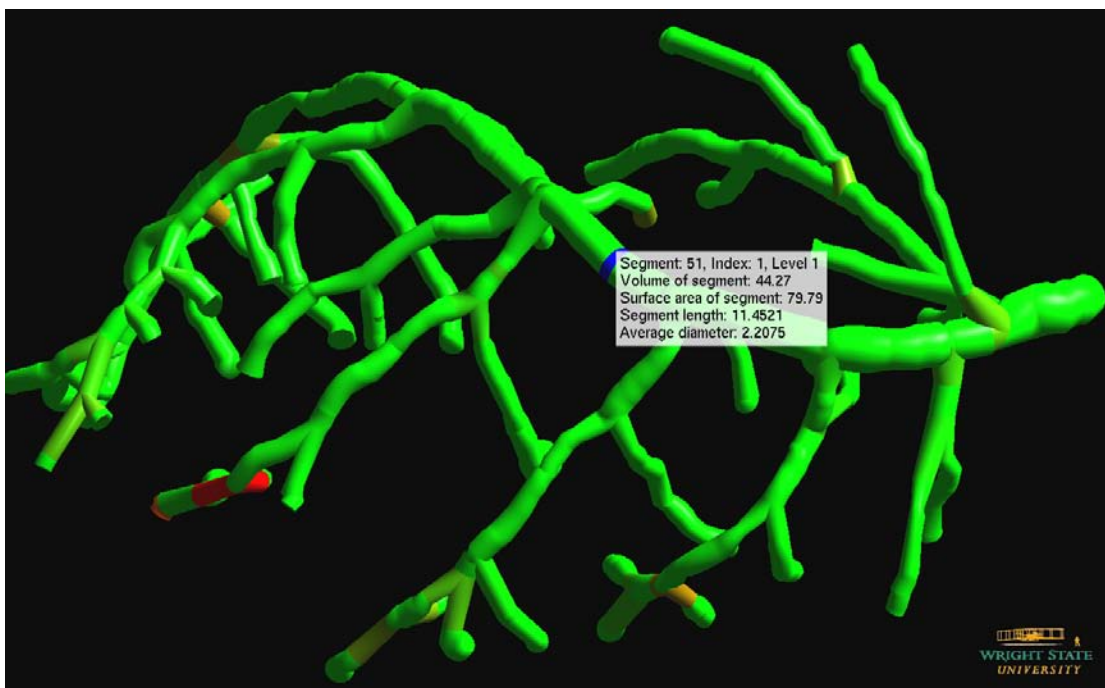

Vessels can be highlighted and details of segments can be shown in an overlay area.

Mental Health

The domain of mental health has been a leader in integrating VE technology into healthcare. The most common use of VE in mental health is for the treatment of anxiety disorders. Fear of flying, fear of heights, fear of spiders, fear of public speaking, claustrophobia, panic disorder with agoraphobia, and post-traumatic stress disorder (PTSD) are examples of anxiety disorders that have been the focus of treatment with VE.²³⁻²⁵

A common treatment for anxiety disorders is exposure therapy in which the patient is gradually exposed to fear-producing stimuli, either imagined or in real life (in vivo).²³ Virtual Reality Exposure Therapy (VRET) is an innovative method of conducting exposure therapy. VRET has been used more frequently in the past ten years as VE systems have become less expensive and more accessible. Users are immersed within a computer-generated simulation or VE and increasingly exposed to the feared stimuli within a contextually relevant setting.²⁵ There are many benefits to VRET compared to in vivo or imaginary exposure. With VRET the therapist has more control and flexibility over the stimuli and can customize the simulation to the individual patient. The patient response to the stimuli can be monitored, and adjustments made immediately. VE allows unlimited access to conditions that in real life may be impractical, difficult, potentially dangerous, or costly. In addition, the patient may feel safer and more in control with VRET because the encounter can be administered in a therapeutic setting and the stimuli can be terminated at any time. VRET can also integrate cognitive, behavioral, and experiential treatment methods simultaneously.²⁴⁻

²⁶ For VRET to be effective, three conditions must be met:

- participants need to feel present;
- the VE has to elicit emotions; and
- extinction and co-occurring cognitive changes have to generalize to real situations.²³

Studies show that VRET is as effective as in vivo exposure for the phobias of fear of heights, fear of flying, and fear of public speaking. VRET has been shown to reduce PTSD symptoms in Vietnam Veterans.²⁷ It has also been used in the treatment of eating disorders.²⁸ Although preliminary research on VRET for anxiety disorders has been favorable, more empirical research is needed. Many studies include VE in conjunction with other treatments; consequently, it is difficult to separate the effectiveness of VRET from co-interventions. Other research concerns regarding VE include standardization in study methods (e.g., number of sessions, type of VE system), additional evidence about long-term effectiveness, and the generalizability of VE to the real world.^{18, 23}

In general, VRET is viewed as relatively effective in reducing anxiety and phobia symptoms in select patients.²⁵ Individuals who suffer from heart disease or epilepsy and those who are taking drugs with major physiological and or psychological effects are at risk for adverse effects from VRET. These patients may need to be excluded during the screening process.²⁴ Although VRET is an application of VE technology centered on the patient as the user, the technology could also be employed for education purposes. In combination with video of patients using the technology, clinicians can learn the appropriate use of the VRET and specific techniques for controlling patient experiences.

Surgical Training

Surgery is another healthcare domain that has benefited from advances in VE and 3D visualization. Traditionally, surgeons have been trained through the apprenticeship method. The use of simulation lessens the risk to patients and decreases time to achieving competency. VE training provides a medium to “train out” the learning curve for technical skills on a simulator rather than on patients.^{29, 30} VE trainers provide a safe and ethical alternative to the use of cadavers and animals. Additionally, a high level of mentoring can be provided in less time.²⁹

Further, the rise of Minimally Invasive Surgery (MIS) has made the apprenticeship model less practical. Both novice and experienced surgeons have benefited from the integration of simulators and VE for training and assessment. Surgeons experienced in open surgery have used VE simulators to update their MIS skills. Experienced surgeons are also benefiting from converting 2D Computed Axial Tomography (CAT) and Magnetic Resonance Imaging (MRIs) scans to 3D visualizations.

In a landmark randomized blinded study, Seymour et al.²⁹ found that the use of VE surgical simulation to reach specific target criteria significantly improved the operating room (OR) performance of residents during laparoscopic cholecystectomy. Residents trained on the VE simulator made fewer errors such as injuring the gallbladder or burning non-target tissue and were more likely to make steady progress throughout the procedure than non VE-trained residents. This study has been seen as a validation of the transfer of training skills from VE to OR.

Other studies have supported VE as a useful tool for evaluating the psychomotor skills needed to perform laparoscopic surgery. VE trained surgeons showed significantly more improvement in performance in the OR than those in control groups in measures of time, errors, and economy of movement.³¹⁻³³ In addition, improvement in technical skills performance was consistent. The simulator objectively measured skill improvement in the ability to automate to the fulcrum effects of the body wall.^{31, 34}

Although VE training has been shown to be effective, it has not been shown that VE training alone is sufficient. It should be a part of a defined, evidence-based curriculum including traditional methods with objective measures of assessment.^{30, 35, 36} Some of the basic skills for laparoscopic surgery that have to be addressed in training are hand-eye coordination, fulcrum effect (perceived inversion of movements), and depth perception. VE training allows users to practice procedural tasks, integration of knowledge, and judgment in a safe environment.³⁰

Gallagher and Satava³¹ made recommendations for development of a training curriculum. Knowledge and psychomotor skills must be acquired together. In addition, interval practice is more effective than massed practice. The metrics should be procedure-specific with errors well defined. A benchmark level of performance determined by observing experienced surgeons is more beneficial than setting a number of repetitions (or cases) or time limit to determine proficiency. Objective feedback should be provided during training sessions, with errors identified as close to the time of occurrence as possible.

Rehabilitation

Cognitive rehabilitation and physical rehabilitation are also areas that have developed applications of VE and 3D technology. When used for assessing the cognitive function of patients with traumatic brain injuries and stroke, VE has been shown to have satisfactory psychometric properties. However, there has been little empirical research to support its effectiveness in rehabilitating cognitive function.¹⁸

With physical rehabilitation, VE has many possible benefits. VE allows for the full range of human gestures as input. All properties of movement can be captured simultaneously, and feedback can be translated to alternate or multiple senses. Using

VE training, researchers at Wright State University and the University of Cincinnati are currently collaborating on an investigation of amputees. They are studying whether amputees can effectively and efficiently ambulate with a more symmetrical gait through improved stride length, more equal weight distribution between limbs, and a more narrow and improved base of support. For this research camera markers are placed on the legs and body of the amputee.

Figure 2a. Amputee gait training



Figure 2b. Example of the avatar patient sees



Spatial-temporal and kinematic data are collected, and an accurate biomechanical model is created into an avatar of the patient, which is presented on a screen or HMD in 3D. The patient is able to view his or her gait in real-time and make corrections. Gait analysis follows to compare gait before and after training. Figure 2a illustrates an amputee with markers, and Figure 2b illustrates the avatar biomechanical 3D model the patient sees.

While the benefit to the patient is obvious, VE for rehabilitation can also support the training of rehabilitation caregivers. VEs allow individuals to be immersed in a real-world environment and facilitate optimal rehabilitation by permitting experts from a variety of clinical areas to assemble as a team and contribute their special knowledge to a patient's care. Currently, there are no standardized rehabilitation programs for amputees, and care can vary greatly depending on the provider's training. Standardized rehabilitation techniques and measures need to be applied consistently across patient care programs to

improve the amputee's outcome and quality of life. Through the combination of expertise and customized programs in a VE training setting, rehabilitation potential is unlimited. For example, a VE training tool that is developed to illustrate ambulatory techniques for different types of amputees will provide a better standard of care.

VE Social Networks

Social VEs are used in healthcare applications as a platform for the education and training of medical professionals and as a means of education and support for patients. Linden Lab's Second Life[®] (SL) (<http://secondlife.com>) is the best known Internet-based VE. SL is becoming more widely used for training and/or therapeutic purposes because it is already established and facilitates customization. In addition, SL is a widely available platform that greatly reduces the cost and time needed for development compared to building the VE from the beginning.³⁷

SL provides innovative methods for training participants in clinical, communication, and interpersonal skills. It has inherent characteristics that are beneficial to medical applications. Collaboration and individual learning are both possible due to an integrated range of communication tools including speech, instant messaging, and text.^{37, 38} Users have the ability to interact with and speak to real people in real time. A unique feature of SL is that the volume of an avatar's voice corresponds to direction and distance.³⁹ For training purposes, this helps replicate real-life factors that can affect communication with patients and team members.

Several institutions have developed training applications for SL. The Heart Murmur Sim, developed by San Jose State University, allows clinical students to practice their skills identifying sounds of different types of heart murmurs. In 2007, the Women's Health Center at the Ann Myers Medical Center became the first SL community credited with including medical simulations. The Virtual Hospital of the Imperial College of London allows students to perform patient interviews, order diagnostic tests, arrive at a diagnosis, and provide treatment and follow-up care. In addition, Imperial College has developed the Second Health project, which includes a clinic equipped with virtual patients, an auditorium for lectures, and a fictional London neighborhood that provides public health messages.³⁹ Other SL examples include paramedic training and disaster preparedness.^{37, 39} These training programs prepare for emergencies and other high stakes events that are rarely seen during normal duties.

In addition to clinical skills, VEs can assist medical personnel gain empathy for their patients. For example, clinicians can experience patients with combat conditions such

as PTSD. A simulation of the auditory and visual hallucinations experienced by schizophrenic patients has also been developed.⁴⁰

VE social networks also have applications in mental health. In particular, patients with agoraphobia or body image issues seem to benefit from the visual self-awareness of seeing themselves in the SL environment in the form of an on-screen avatar. Mental health providers can also meet with patients “in-world” in avatar form.

SL also provides a mechanism for patient education and support. As a social-networking site, SL can allow patients to meet in virtual support groups. Currently, among the support organizations in SL format are ones for autism, cerebral palsy, and child abuse survivors. Patients can interact anonymously with others with similar diagnoses. SL can also be used to educate patients about their health issues. Currently, several agencies, including the US Center for Disease Control and Prevention, have a presence in SL. The National Library of Medicine established HealthInfo Island, which provides health-related education resources. Medical professionals set times during which they are available to answer questions, give live lectures, or post pre-recorded presentations.

SL’s potential is due to two factors: (1) its flexibility in providing alternative education techniques beyond traditional didactic approaches and (2) its ability to present information in a dynamic way that allows for experiential learning. Interactive games and scenarios can provide lessons on healthy lifestyle choices in the context of real-life situations. One example is the Nutrition Game developed by Ohio University. Users make healthy food choices and learn about the impact of fast food.³⁸ Similarly, games can be developed to teach patients other healthy lifestyle choices or topics for managing specific illnesses (e.g., diabetes). VEs provide a safe place for patients to experience the external factors that can cause them problems or ambiguity. With a well-designed game or the presence of a facilitator, users will receive immediate feedback and information about their choices. Thus, VEs provide an alternative for patients who typically contact their healthcare providers with their inquiries.

Further, the use of SL can be expanded by connecting objects in the real world to the virtual world. For example, by integrating a high fidelity mannequin simulator into SL,

users can practice hands-on skills while experiencing scenarios in the VE. SL can also be used as an extension of telemedicine. With the use of sensors and in real time, the physician can learn about her patient's physiological state and use this information to monitor real-life scenarios.⁴¹

As with any use of the Internet, there are safety issues to address. The benefit of SL is that it allows for the creation of a closed environment where only invited guests have access. There are concerns that the use of VEs could become addictive for some patients. There are also risks that people may misrepresent themselves as a patient or initiate contact outside of the virtual world. Research on the use of SL is in initial stages. At this time, it is advised that SL and other VEs only be used in conjunction with traditional methods or perhaps as follow-up care. Adequate training for mental health professionals and patients is another issue that must be factored into using SL or other VEs for therapeutic purposes.

Other Applications

There are other VE applications that can benefit healthcare. The ability to visualize physical layouts in healthcare settings such as operating rooms, emergency rooms, laboratories, and patient waiting areas can help in the planning of work tasks and process flow before a physical facility is actually established. The arrangement of rooms and other space can be explored in actual size in an immersive environment. Visualizing the flow of personnel, patients, and materials helps administrators and practitioners plan a physical facility that will assure an efficient and effective healthcare operation. The use of VEs is only limited by one's imagination.

Evaluations/Outcome Measurements

VEs can vary from low to high fidelity. The level of fidelity needed for accurate training is a question that has been, and continues to be, asked across many domains. On the continuum of fidelity, from low to high, positive outcomes depend on the purpose of the training and how effectiveness is measured.

The evaluation of effectiveness is a critical aspect of VEs. Evaluation may include Transfer of Training (ToT). Measuring ToT can be expensive, but it is important for developing useful training and assessing cost-benefit trade-offs. Other types of

measurement are also important. For example, if the system shows negative transfer, additional forms of measurement can be used to identify how to mitigate this unwanted outcome. Table 2 provides examples of measurements to consider when evaluating VEs.

Table 2. Measurements to consider when using VEs.

Measurement	Description
Transfer of Training (ToT)	Two-group, self-control, pre-existing control, subjective opinion, uncontrolled, low fidelity to high fidelity, exams for knowledge, etc. ⁴²
Human Performance Measures	Objective performance measures related to the specific task (skill measures), time, accuracy/errors, mental workload, critical incidents, eye movements/head movements, performance lags, situation awareness, team performance measures, sensation of presence, subjective opinions, manual tracking performance, less resistance to training, enjoyment of training, spending more time training
Physiological	Visual and motor aftereffects, vestibular aftereffects Cybersickness (Cybersickness questionnaire, EMG), physiological monitoring (heart rate, sweating, blood pressure, EEG, EMG of stomach, etc.), length of time to adapt, length of time in the VE, length of time of aftereffects
Social	Amount of interactions among users, type of information shared, social enhancement effects on clinical outcomes, increased motivation
Software and Hardware Measures	System lags, system crashes or failures, processing performance, packages sent across distributed systems

Future Practice

As indicated previously, VE technology changes rapidly. The use of low and medium fidelity VEs is likely to increase more rapidly than high fidelity, high cost systems. Moving the development of VE technology into usable practice will require a multidisciplinary strategy to define and integrate VE requirements, applications with clinical needs, and educational expertise. For example, easy-to-obtain and inexpensive 3D modeling and visualizations are needed for use in a variety of applications and training situations. User-friendly software tools for more rapid creation of VE training systems are also important for moving the technology further, faster.

The development of VE training systems for healthcare education will not likely originate at schools of medicine and other healthcare professions. Due to a lack of funding, U.S. healthcare training institutions traditionally do not produce, but rather purchase, existing systems. Progress in VE technology development will come from the entertainment industry (movies and games) and the Department of Defense (DoD) before progressing to healthcare companies for purchase by the healthcare professions.

Cost

The hardware, software, and other costs of VE systems vary with the complexity of the technology, the application setting, and training requirements. While low cost systems can be built, including ones with HMDs and 3D displays, for between \$200 and \$50,000, the cost for an immersive four-wall space with software, trackers, input devices, and audio can range from \$880,000 to several million depending on the specifications. Also, while software toolkits can cost as much as 50,000, graphics programmers can create VEs with less expensive graphics and software languages. A three-dimensional mouse can be purchased for less than \$100. Tracking systems range in price from \$1,100 to \$8,000. Thankfully, the cost of VEs continues to decrease as the technology advances and applications diversify.

Conclusion

Virtual environments will have a prominent place in the future of health professions education. The development and use of VEs can be complex and require a multidisciplinary team of subject matter experts and engineers from human factors and software/hardware development. Educators can benefit from the advantages of VE for training if they (1) understanding human sensations, perceptions, and capabilities, (2) specify educational goals and competencies, (3) apply needed hardware and software, and (4) utilize multiple measures of performance to determine learning effectiveness or Transfer of Training. Since VEs can be costly, planning is essential, but the future of this advanced technology is virtually limitless.

Acknowledgements

The authors would like to thank Thomas Wischgoll, PhD, Wright State University, for Figure 1 and Maurissa D'Angelo, PhD candidate in Engineering at Wright State University, for Figures 2a and 2b.

References

1. Burdea G, Coiffet P. Virtual reality technology. Hoboken, NJ: John Wiley & Sons; 2003.
2. Sutherland IE. The ultimate display. *Proceedings of the International Federation for Information Processing Congress*; New York, May 1965:506-508.
3. Melzer JE, Moffitt K. Head-mounted displays: designing for the user. New York, NY: McGraw-Hill; 1997.
4. Rash CE, Russo MB, Letowski TR, et al., eds. Helmet-mounted displays: sensation, perception and cognition issues. Ft. Rucker, Alabama: U.S. Army Aeromedical Research Laboratory; 2009.
5. Foxlin E. Motion requirements and tracking technology. In: Stanney KM, ed. Handbook of virtual environments: design, implementation, and applications. Mahwah, NJ: Lawrence Erlbaum Associates; 2002:163-210.
6. Aliakseyeu D, Subramanian S, Martens J, et al. Interaction techniques for navigation through and manipulation of 2D and 3D data. *Proceedings of the 8th Eurographics workshop on virtual environments*; Barcelona, Spain, May 2002:179-188.
7. Hachet M, Guitton P, Reuter P. The CAT for efficient 2D and 3D interaction as an alternative to mouse adaptations. *Proceedings of the Association for Computing Machinery symposium on virtual reality software and technology*; Osaka, Japan, October 2003:205-212.
8. Grossman T, Balakrishnan R. Pointing at trivariate targets in 3D environments. *Proceedings of the Association for Computing Machinery SIGCHI (Special Interest Group on Computer Human Interaction) conference on human factors in computing systems*; Vienna, Austria, April 2004:447-454.
9. Hinckley K, Pausch R, Proffitt D, et al. Two-handed virtual manipulation. *ACM Transactions on Computer-Human Interaction* 1998; 5:260-302.

10. Qi W, Martens J, Liere RV, et al. Reach the virtual environment: 3D tangible interaction with scientific data. *Proceedings of the 17th conference of the computer-human interaction special interest group (CHISIG) of Australia*; Canberra, Australia, November 2005:1-10.
11. Schkolne S. 3D Interfaces for spatial construction. Dissertation: California Institute of Technology; 2004.
12. van Rhijn A, Mulder JD. Spatial input device structure and bimanual object manipulation in virtual environments. *Proceedings of the Association of Computing Machinery symposium on virtual reality software and technology*; Limassol, Cyprus, November 2006:51-60.
13. Xu S, Li Z, Salvendy G. Individualization of head-related transfer function for three-dimensional virtual auditory display: a review. Lecture notes in computer science. *Proceedings of the Second International Conference on Virtual Reality*. Springer 2007; 4563:397.
14. Westebring-van der Putten EP, Goossens RHM, Jakimowicz JJ, et al. Haptics in minimally invasive surgery - a review. *Minim Invasive Ther Allied Technol* 2008; 17:3-16.
15. Hayward V, Astley OR, Cruz-Hernandez M, et al. Haptic interfaces and devices. *Sens Rev* 2004; 24:16-29.
16. Roberts WK. A predictive model of cybersickness in human virtual environment interaction. Dissertation: Wright State University; 2004.
17. Welch RB. Adapting to virtual environments. In: Stanney KM, ed. *Handbook of virtual environments: design, implementation and applications*. Mahwah, NJ: Lawrence Erlbaum Associates; 2002:619-636.
18. Riva G. Virtual reality for healthcare: the status of research. *Cyberpsychol Behav* 2002; 5:219-225.
19. Wischgoll T, Choy JS, Ritman E, et al. Validation of image-based extraction method for morphometry of coronary arteries. *Ann Biomed Eng* 2008; 36:356-368.
20. Huo Y, Kaimovitz B, Lanir Y, et al. Biophysical model of spatial heterogeneity of myocardial flow. *J Biophys* 2009; 96:4035-4043.
21. Wischgoll T, Choy JS, Kassab GS. Extraction of morphometry and branching angles of porcine coronary arterial tree from CT-images. *Am J Physiol Heart Circ Physiol* 2009; 297:H1949-H1955.

22. Wischgoll T, Meyer J, Kaimovitz B, et al. A novel method for visualization of entire coronary arterial tree. *Ann Biomed Eng* 2007; 35:694-710.
23. Krijn M, Emmelkamp P, Olafsson R, et al. Virtual reality exposure therapy of anxiety disorders: a review. *Clin Psychol Rev* 2004; 24:259-281.
24. Gregg L, Tarrier N. Virtual reality in mental health: a review of the literature. *Soc Psychiatry Psychiatr Epidemiol* 2007; 42:343-354.
25. Parsons TD, Rizzo AA. Affective outcomes of virtual reality exposure therapy for anxiety and specific phobias: a meta-analysis. *J Behav Ther Exp Psychiatry* 2008; 39:250-261.
26. Riva G. Virtual reality in psychotherapy: review. *Cyberpsychol Behav* 2005; 8:220-230.
27. Rothbaum BO, Hodges LF, Ready D, et al. Virtual reality exposure therapy for Vietnam veterans with posttraumatic stress disorder. *J Clin Psychiatry* 2001; 62:617-622.
28. Riva G. Applications of virtual environments in medicine. *Methods Inf Med* 2003; 42:524-534.
29. Seymour NE, Gallagher AG, Roman SA, et al. Virtual reality training improves operating room performance: results of a randomized, double-blinded study. *Ann Surg* 2002; 236:458-464.
30. Aggarwal R, Grantcharov TP, Eriksen JR, et al. An evidence-based virtual reality training program for novice laparoscopic surgeons. *Ann Surg* 2006; 244:310-314.
31. Gallagher AG, Satava RM. Virtual reality as a metric for the assessment of laparoscopic psychomotor skills. *Surg Endosc* 2002; 16:1746-1752.
32. Grantcharov TP, Kristiansen VB, Bendix J, et al. Randomized clinical trial of virtual reality simulation for laparoscopic skills training. *Br J Surg* 2004; 91:146-150.
33. Haque S, Srinivasan S. A meta-analysis of the training effectiveness of virtual reality surgical simulators. *IEEE Trans Inf Technol Biomed* 2006; 10:51-58.
34. Patel AD, Gallagher AG, Nicholson WJ, et al. Learning curves and reliability measures for virtual reality simulation in the performance assessment of carotid angiography. *J Am Coll Cardiol* 2006; 47:1796-1802.
35. Gallagher AG, Ritter EM, Champion H, et al. Virtual reality simulation for the operating room: proficiency-based training as a paradigm shift in surgical skills training. *Ann Surg* 2005; 241:364-372.

36. Sutherland LM, Middleton PF, Anthony A, et al. Surgical simulation. *Ann Surg* 2006; 243:291-300.
37. Conradi E, Kavia S, Burden D, et al. Virtual patients in a virtual world: training paramedic students for practice. *Med Teach* 2009; 31:713-720.
38. Boulos MNK, Hetherington L, Wheeler S. Second Life: an overview of the potential of 3-D virtual worlds in medical and health education. *Health Info Libr J* 2007; 24:233-245.
39. Beard L, Wilson K, Morra D, et al. A survey of health-related activities on second life *J Med Internet Res.* 2009; 11: e17. Available at: <http://www.jmir.org/2009/2/e17>. Accessed February 1, 2010.
40. Yellowlees PM, Cook JN. Education about hallucinations using an Internet virtual reality system: a qualitative survey. *Acad Psychiatr* 2006; 30:534-539.
41. Gorini A, Gaggioli A, Vigna C, et al. A second life for eHealth: prospects for the use of 3-D virtual worlds in clinical psychology. *J Med Internet Res* 2008; e21 p10. Available at: http://www.jmir.org/article/view/jmir_v10i3e21. Accessed February 1, 2010.
42. Lantham CE, Tracey MR, Sebrechts MM, et al. Using virtual environments as training simulators: measuring transfer. In: Stanney KM, ed. *Handbook of virtual environments design, implementation and applications*. Mahwah, NJ: Lawrence Erlbaum Associates; 2002:403-414.

About the Authors

Jennie J. Gallimore, PhD is the Director of the Ohio Center of Excellence for Human-Centered Innovation at Wright State University and Professor of Industrial and Human Factors Engineering, College of Engineering and Computer Science, Wright State University. She holds a joint appointment as a Professor of Surgery in the Boonshoft School of Medicine at Wright State University. She applies her expertise of humans in complex systems across many domains including healthcare, aviation, and process control. Among her research interests are the development of virtual environments and synthetic agents such as virtual patients, design of interactive visualizations, and visual interfaces to support human decision-making.

April L. Barnes, MS is a candidate for the PhD in Engineering in the Department of Biomedical, Industrial and Human Factors Engineering, College of Engineering and Computer Science, Wright State University. She has a M.S. in Human Factors Engineering from Wright State University and a B.S. in Psychology from The Ohio State University. Her dissertation research focuses on the development of virtual patients for training communication skills.

Rosalyn P. Scott, MD, MSHA is the Associate Chief of Staff for Medical Education and Director of the Simulation Center at the Dayton VAMC and Professor of Surgery at the Boonshoft School of Medicine, Wright State University. She holds a joint appointment as a Professor of Biomedical, Industrial and Human Factors Engineering in the College of Engineering and Computer Science at Wright State University. Her simulation-based research interests are in the areas of mixed reality simulations and interactive virtual patients. She is also on the Board of Directors of the MedBiquitous Consortium, an ANSI-accredited developer of information technology standards for healthcare education and competence assessment.

Process Modeling Using Simulation

Pratik J. Parikh, Praveen Chawla, Kashyap Mehta and Rosalyn P. Scott

Introduction

Health systems are inherently complex and dynamic. A healthcare decision-maker is faced with numerous decisions ranging from strategic decisions, such as where and how many health facilities to locate and what medical services to offer, to operational decisions, such as managing patient flow, allocating resources, and improving quality of care. A decision-maker may use his/her experience and intuition to make these decisions, but such an approach may lead to suboptimal results. When confronted with a situation, individuals look for a precedent among past actions regardless of circumstances. Mistakes tend to be repeated with potentially severe repercussions on quality of care and/or costs.

Recently, decision support systems that rely on mathematical modeling of relationships between various activities of a health system have been proposed and successfully implemented. Some of these quantitative techniques include mathematical programming and simulation. Mathematical programming prescribes the optimal system configuration, but fails to accurately capture uncertainty in the data and the dynamics of the system. For this reason, simulation, which can be dynamic, has emerged as a popular mathematical tool to analyze complex, multidimensional, health systems.

For this discussion we are using the term simulation to represent “a technique for using computers to imitate/simulate the operations of various kinds of real-world facilities or processes.”¹ Simulation offers hospitals, health systems, clinics, and healthcare consultants the ability to perform accurate, highly detailed predictive analyses of the specific and systemic impact of operational, process, and layout changes before decisions are made. As stated by Eldabi,² “simulation can provide deeper insights into the barriers and incentives to adoption (and hence spread of good practice) that could subsequently be tested in field environments.” Through simulation, one can examine the complex and numerous effects of proposed changes that may impact patient flow analysis, staff utilization and efficiencies, resources, bed

and spatial demand patterns, ancillary departments, interrelated capacity and flow constraints, and throughput and wait times.

Simulation tools offer a level of detail, accuracy, and quantitative analysis that is unavailable through spreadsheets, flowcharts, and traditional consulting methodologies. Via *what-if* scenario analysis, options to various problems and issues can be examined, compared, adjusted, and fully understood. Further, since they are objective and quantitative, simulations are invaluable tools for solving contentious issues using precise analytics. Figure 1 indicates the steps involved in conducting a successful simulation study, which includes process mapping and data collection, modeling the dynamic behavior of healthcare entities, conducting simulation runs, and analyzing results.

Figure 1. Steps involved in conducting a simulation study – Example of an emergency department.

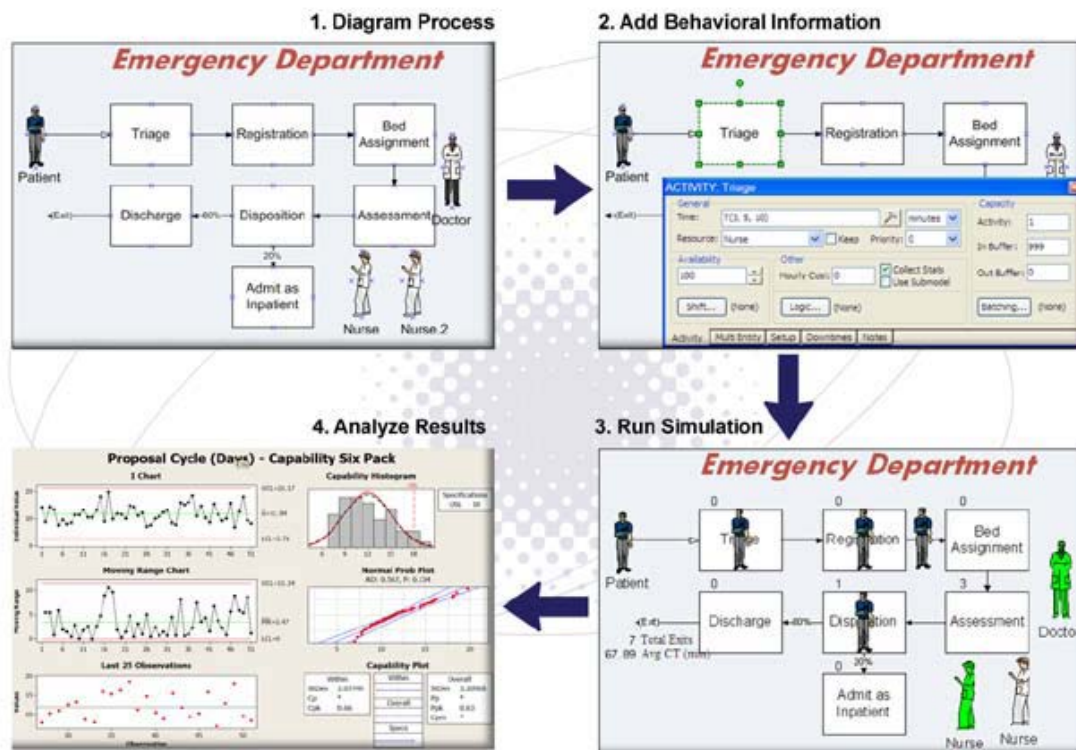

(Available at: http://www.promodel.com/solutions/healthcare/White_Paper_Simulation_for_Lean_Six_Sigma_in_Healthcare.pdf Accessed on February 1, 2010.)

Healthcare systems typically have dynamic, stochastic, and discrete characteristics for which a corresponding simulation model, typically referred to as a discrete-event simulation (DES), is suitable. Our discussion will be focused on such models with reference to their applicability in modeling healthcare processes.

Simulation in Modeling Health Care Processes

Simulation tools have been used to address a number of problems in the healthcare domain, ranging from the strategic to operational. Below we summarize reports that involve applications of simulation as a tool to solve problems in planning, scheduling, and related matters. We point the reader to recent review articles by Jacobsen et al.³ and Eldabi et al.² for a more comprehensive exposition of simulation modeling in healthcare.

Capacity Planning

Healthcare capacity or asset planning is a crucial strategic and tactical decision that has major cost implications. Capacity planned considering only peak workloads may lead to under-utilization of resources, while capacity planned for average workloads may limit the resources available for the number of patients served by the health system. Discrete-event simulation can play a crucial role in planning for varying capacity throughout a health system. Furthermore, the operational implications of these decisions can be simulated rapidly over long periods of times, which may facilitate measuring the total cost and quality of care. For this discussion we will use bed, room, and staff planning decisions as exemplars.

Bed and Room Planning

When planning number of beds, hospitals struggle with two conflicting objectives: having sufficient beds to serve the relatively unpredictable needs of patients and maximizing bed utilization.³ Figure 2 shows an example of a DES model for bed planning using Anylogic simulation software.

To determine the impact of an increase in number of post-anesthetic beds (PABs) on surgery delays, Ferreira et al.⁴ developed a DES model of the Rio de Janeiro hospital's surgical center in Brazil. They measured many factors that could cause surgery delays, including the patient throughput, number of surgeries per day,

Figure 2. A simulation model for bed planning.

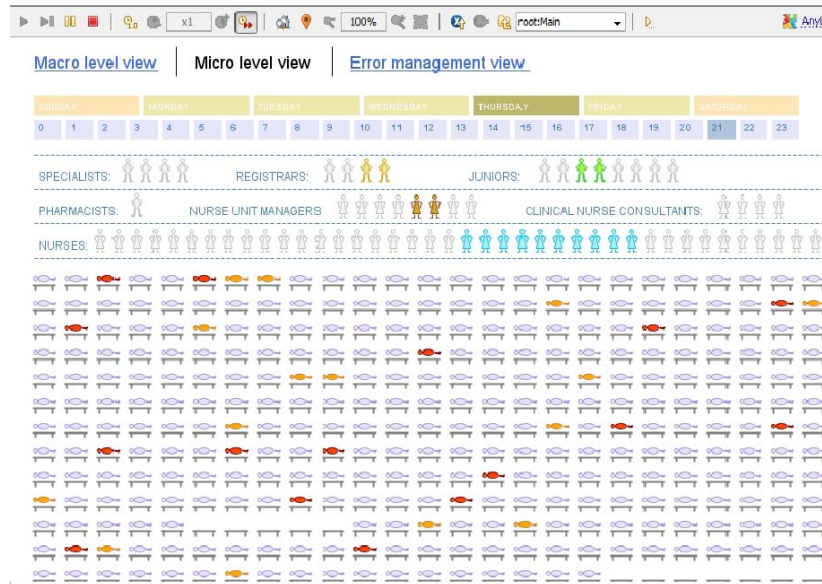

(Available at: <http://www.xjtek.com/>. Accessed on February 1, 2010.)

cleaning and disinfection of the surgical room, and hospital administrative practices. They considered two types of scheduling policies: 1) rigid scheduling, where rooms previously assigned to surgical teams could not be changed and 2) flexible scheduling, where a surgical room, whenever available, could be used by any surgical team. By keeping the same number of PABs and using flexible scheduling, the authors observed that nearly 38 surgeries could be performed daily, rather than the current 25, if no delays occurred.

Troy and Rosenberg⁵ considered a problem at the Jewish General Hospital in Montreal, Quebec, which has a total of 637 beds, of which 14-16 staffed beds are for the combined Medical-Surgical Intensive Care Unit (ICU). This hospital had previously canceled all elective procedures known to require a one-week ICU stay due to a mismatch in the demand and supply of ICU beds. In this study the authors considered both the actual capacity (i.e., total number of ICU beds) and the functional capacity (i.e., the number of occupied ICU beds at which scheduled procedures known to require an ICU stay are canceled). Using their DES model of the ICU, they concluded that actual and functional ICU capacity jointly explained ICU utilization and the mean number of patients that should have been in the ICU who were parked elsewhere. Following the authors' recommendation, hospital management, increased

staffing from 14-16 actual beds and 13-15 functional beds to 18-20 actual beds and 17-19 functional beds.

There are additional examples of simulation as a tool for planning bed capacity. Marcon et al.⁶ devised a simulation flow model to calculate the minimum number of beds required in the post anesthesia care unit (PACU). In a simulation study Akkerman and Knip¹ provided insights into the relationships among a patient's length of stay, bed availability, and hospital waiting lists. Masterson et al.⁷ developed a DES model of the intensive care unit (ICU) at the US Air Force's Wilford Hall Medical Center (now San Antonio Military Medical Center South) to analyze the impacts of ICU size and bed mix, operating policies, and the deployment of ICU staff on measures of occupancy, congestion, and physician training needs.

Staff Planning

Staff planning refers to planning for doctors, nurses, and other clinical and non-clinical personnel who support the various activities at a medical facility. DES has been used in determining staffing levels that depend on changes in workload. Figure 3 is an example of a capacity planning model using DES

Figure 3. Capacity planning using simulation.

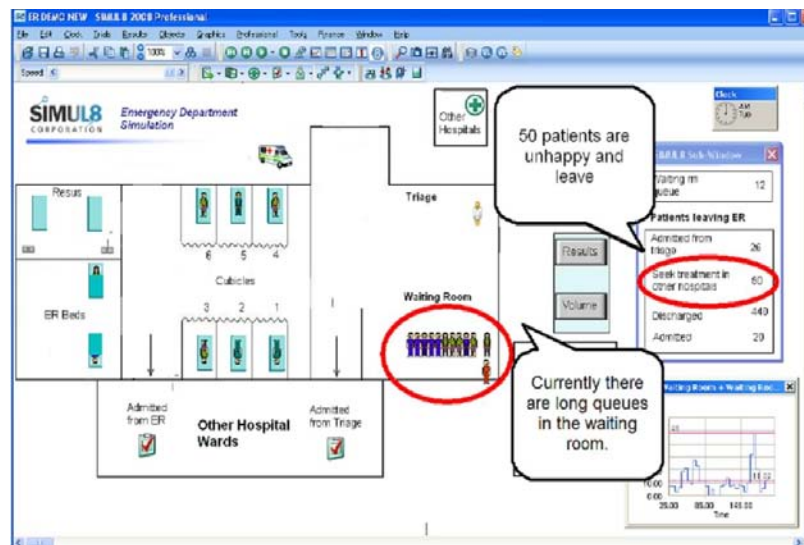

(Available at: <http://www.simul8.com>. Accessed on February 1, 2010.)

modeling capability in Simul8 simulation software. A few applications of DES used for staff planning follow. Elkhuisen et al.⁸ analyzed the capacity needed in the neurology

and gynecology departments in an appointment-based hospital facility, the Academic Medical Center in the Netherlands. The objective was to meet the benchmark of seeing 95% of all new patients within two weeks. Using a simulation model, they determined that for the neurology department to eliminate the six-week backlog, 26 extra consultations per week were needed over two months. A permanent increase of two additional consultations per week was required to keep access time within two weeks. The gynecology department had sufficient capacity, but the same service level could now be achieved with 14% less capacity. The authors conclude that the added value of the simulation model, over their earlier analytical model, was the ability to account for variations in demand for different weekdays and to develop a realistic schedule for doctors' consultations.

In studying staffing for operating rooms (OR), Van Oostrum et al.⁹ recognized that hospitals are often challenged with how to decide optimal staffing, especially for emergency surgery during the night. They developed a DES model to determine the optimal team composition during the night for the main OR of Erasmus University Medical Center in the Netherlands. The objective was to minimize staffing cost, while providing adequate resources for surgery. They modeled the safety interval of a surgical procedure - i.e., the time frame within which a patient must have his operation. For example, a patient with a ruptured abdominal aortic aneurysm should be operated on within 30 minutes of arrival at the hospital, while a patient with a perforated gastric ulcer should be operated on within three hours of arrival. They additionally observed that the staffing levels could be reduced by as much as 47% depending on other criteria, such as delay in surgeries.

Similar challenges face providers of emergency care. Baesler et al.¹⁰ used process modeling strategies to predict a patient's time spent in the emergency room of a private hospital in Chile to minimize the number of resources required to meet patient demand. Similarly, Centeno et al.¹¹ developed an optimal schedule for emergency room staff through the use of DES and integer programming. Their study showed a 28% improvement over the method of staffing being used.

Patient Flow Analysis

The analysis of patient flow at a healthcare facility is a complex task. The complexity is due to a number of factors: 1) need for a large amount of data to produce meaningful results, 2) variety of services provided to the patients at a healthcare facility, 3) layout of the facility, and 4) allocation of resources. Figure 4 shows a DES model for analyzing the flow of patients in an emergency room using FlexSim HC simulation software.

Huschka et al.¹² suggest that the layout of a facility can impact the flow of patients considerably. In studying an Outpatient Procedure Center (OPC) that performs pain medicine procedures at the Mayo Clinic, they focused on the issues of patient flow and facility layout. To accomplish a smooth flow of patients through the OPC, a new

Figure 4. 3D model of an ER.

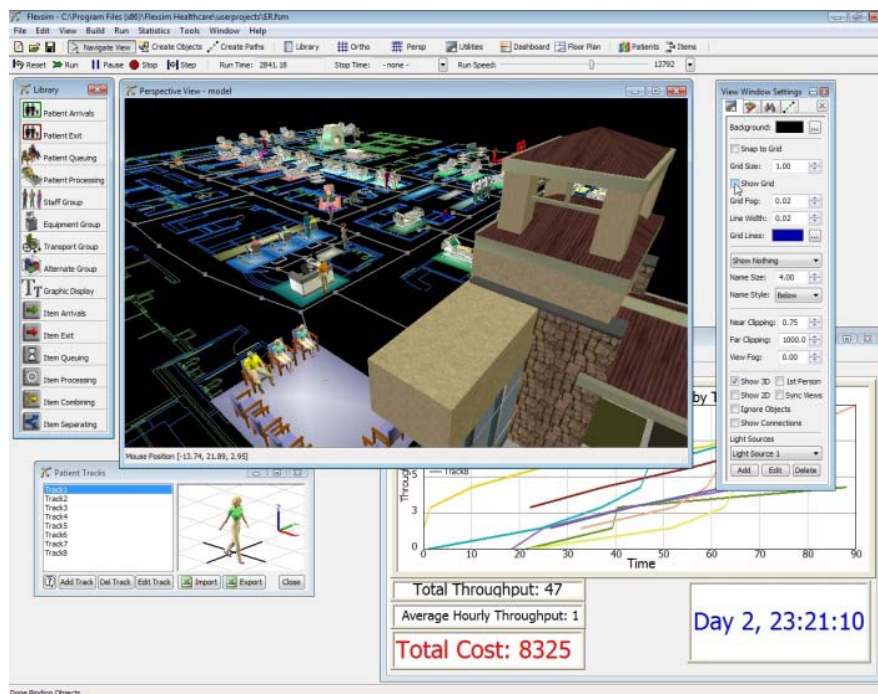

(Available at: <http://www.flexsim.com/>. Accessed on February 1, 2010.)

layout was proposed in which booths for assessing vital signs and recovery rooms were introduced to replace the existing pre/post procedure rooms and procedure rooms. Since the size of the vitals booths and recovery rooms were smaller than the pre/post procedure rooms, additional physical space was available for other uses. A

DES model of the original layout was used as the basis for analyzing design issues for the new layout. It was found that the new layout reduced the waiting time but would occasionally require additional recovery area. This problem was solved by using the new layout's extra space for recovery.

In a study of ICU load leveling, Kolker¹³ argued that elective surgeries are a basic and practical problem. Patient flow is affected by the competition for OR time between elective surgeries and emergency procedures. In examining how to reduce diversion in an ICU with fixed bed capacity, he developed an ICU patient flow simulation model to establish a quantitative link between daily ICU load leveling of elective surgeries and ICU diversions due to beds not being empty. Three types of surgeries were considered: emergency, add-on, and elective. Emergency and add-on surgeries do not have a fixed schedule, whereas elective surgeries could be delayed safely for 24 hours or longer. After considering several what-if scenarios for the system, Kolker suggested bumping 'extra' elective surgeries within a two-week period, scheduling five or fewer elective surgeries per day, and strict adherence to the ICU admission/discharge criteria.

Changes in practice and policy can impact patient flow. When maternity length of stay was to be minimized at Miami Valley Hospital in Dayton, Ohio, Johnson¹⁴ used a DES model to examine the combined effect of this new expectation and physician practices on patient flow and maternity unit census. His analysis showed that a 15% to 20% increase in patient volume and more balanced utilization of all areas within the unit could be realized through minor changes in the maternity unit configuration. Ramakrishnan et al.¹⁵ developed a DES model to analyze different what-if scenarios for the Wilson Memorial Regional Medical Center in Broome County, NY. By making changes within the CT scan area, they demonstrated an increase in patient throughput by 20% while simultaneously reducing report generation time by over 30%.

Scheduling

Scheduling can be viewed from the perspective of the provider or the patient - i.e., scheduling doctors and nurses in anticipation of the demand or scheduling patients given a fixed number of staff. Takakuwa and Wijewickrama¹⁶ considered the problem

of scheduling doctors with a dual objective of minimizing patient waiting time and doctor idle-time at Nagoya University Hospital in Japan. They developed a DES model of the planned outpatient ward to obtain the best schedule mixes of doctors for a given set of scenarios. A data-generator based on the actual patient waiting time for the available doctor, tests, and inspections was devised to serve as input to the DES model. The performance measure of interest in this simulation model was the average patient waiting time (APWT). The model included constraints such as upper and lower limits to the hospital's physicians and other staff required by institutional policies and budget. They found that when the same number of doctors was scheduled, differently, the APWT was reduced by 40% compared to previous practice.

With the goal of reducing the average waiting time of patients and improving the quality of the healthcare, Patvivatsiri et al.¹⁷ used DES to schedule nurses for the Emergency Department of York Hospital in York, PA. Their model considered three hospital units: Critical Care, Intermediate Care, and Alternate Care. They developed a flexible scheduling plan for nursing staff that yielded a 33% improvement in the quality of care and a 53% reduction in average waiting time.

From a patient-scheduling perspective, Rohleder and Klassen¹⁸ conducted a simulation study of rolling horizon appointment scheduling by considering two common management policies: Overload Rules and Rule Delay. The Overload Rules policy considers scheduling methods such as overtime and double-booking, while the Rule Delay policy determines when to implement Overload Rules. The authors proposed a matrix that links resource utilization to client-service measures (such as in-office waiting time and days to obtain an appointment) to support managerial decisions. For example, their study showed that double-booking could significantly increase client waiting time (by up to an average of 8 minutes per patient) compared to using overtime. If management wants to decrease the time it takes clients to get an appointment, then the implementation of an overloading rule can improve performance by up to an average of half a day. Groothuis et al.¹⁹ compared the 'as-is' scheduling procedure for a hospital cardiac catheterization lab, where no patient was scheduled after 4:00 p.m., with a new scheduling procedure of fixing the number of

patients scheduled each day. For the academic hospital examined, they concluded that the 'as-is' scheduling procedure resulted in less overtime compared to fixing the number of patients per day. Further, they found that if some patient preparation was performed outside the catheterization room before and after the intervention, on average, two additional patients could be treated with fewer working days being longer than eight hours.

Other Applications

DES is not limited to planning capacity, scheduling doctors and nurses, or analyzing patient flow, but has also been used successfully to model patient pathways, locations of medical services, and inventory management. Pilgrim et al.²⁰ developed a DES model of the patient pathway for colorectal cancer, from patient presentation through referral, diagnosis, treatment, follow-up, potential recurrence, treatment of metastases, and end-of-life care. The authors showed that their five options were expected to both decrease costs and increase quality-adjusted life years as compared to the current bowel cancer service. These options include the introduction of an Enhanced Recovery Program, increasing the use of colonoscopy as an alternative to flexible sigmoidoscopy for diagnosis, improving surgical expertise/pathology, and two hypothetical options for improving chemotherapy regimens.

Ramwadhoebe et al.²¹ tried to determine whether implementing ultrasound screening for developmental dysplasia (especially, dysplasia of the hip) at infant health care centers (IHCs) is feasible and cost-effective. They developed a DES model of the pathways for pediatric ultrasound screening for hip dysplasia. Two policies, one where the screening centers are located at the IHC and one that uses a centralized screening center, were compared by incorporating aspects such as travel time, consultation time, probability of adherence, and parental attendance. They concluded that although centralized screening centers reduce the workload at the IHC, parental attendance declines due to additional travel.

Simulation can also be used to manage pharmacy and blood banking protocols. Yurtkuran and Emel²² used simulation to better manage and reduce costs related to treatments and drugs. Their analysis showed that a software update that allowed nurses or doctors to record orders for the following day would reduce the turnaround

time for the orders by 36%. Katsaliaski and Brailsford²³ analyzed ordering policies for better managing the blood inventory system at a hospital supplied by a regional blood center. Through a DES model, they identified ordering policies that led to an 89% reduction in RBC outdates, cost savings of 8%, 47% fewer shortages, 88% fewer mismatches that could cause complications, and a 29% reduction in ad-hoc and emergency orders from the hospital.

In summary, for over two decades simulation has been used in the healthcare arena for addressing numerous design and planning issues. We highlighted a few recent reports that show the potential of simulation to capture the complexities inherent in healthcare systems and to aid decision-makers in their efforts to minimize cost and maximize quality of care. Next, we present two real-world implementations of simulation at health systems in the Dayton, Ohio region.

Case Studies

Two projects conducted by Edaptive Computing provide concrete examples of how modeling and simulation have been utilized to improve healthcare processes.

Case 1: Optimizing Length of Stay of Patients in the Emergency Department

Objective: Edaptive was asked by a hospital network to analyze the Emergency Department (ED) process to determine cost-effective methods for reducing the average length of stay (LOS) to 180 minutes or less.

Methods: Key tasks included:

- Creation of a computer sensible model of the ED process using data previously collected through application of lean methodology.
- Simulate the model to assess the impact of potential changes on LOS.
- Recommend cost-effective changes to achieve the LOS goal.

Figure 5 shows a snapshot of the computer model and visualization of its key parameters through simulation.

Figure 5. Modeling and visualization of Emergency Department process.

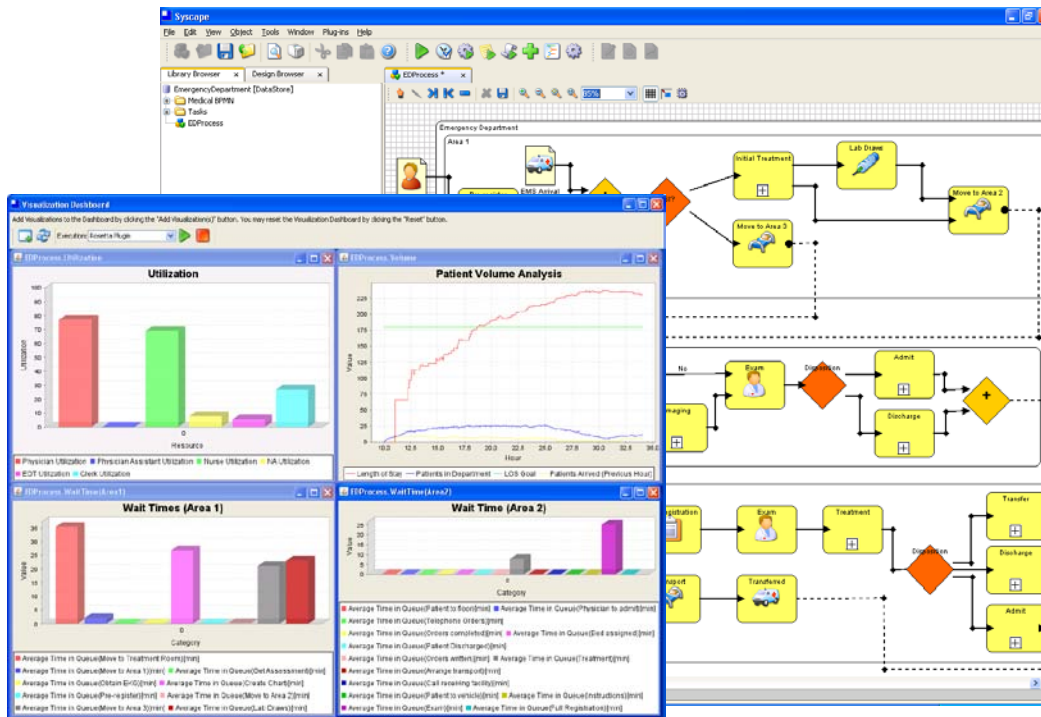

Results: After analyzing several possible changes to the ED process and resources such as beds, doctors, and nurses, it was determined that static resource allocation creates inefficient resource utilization – some resources are over-utilized and some are under-utilized. Furthermore, using simulation, it was found that real-time resource movement between process areas will minimize cost and still achieve the LOS goal.

This project demonstrated that computer modeling can be used as a real-time dashboard to assess status and make sound resource allocation decisions in real-time. The optimization of resources recommended by the model can lead to increased productivity by reducing LOS and enhancing the utilization of resources. A real-time dashboard provides “future-cast” capability, permitting the simulation of a future state based on the current state and contemplated changes.

Case 2: Emergency Preparedness Planning

Objective: To analyze and optimize process workflows and resources in a Neighborhood Emergency Help Center (NEHC) set up at a mass gathering event.

Methods: Processes and resources at an NEHC were modeled and simulated under various types and rates of casualties and the resources available prior to a mass

gathering event. Figure 6 shows the top level view of the process used in an NEHC. Data were then collected at the mass gathering event to verify that the model was accurate and that the simulation results obtained prior to the event were close to reality.

Figure 6. Computer model representing Neighborhood Emergency Health Center process.

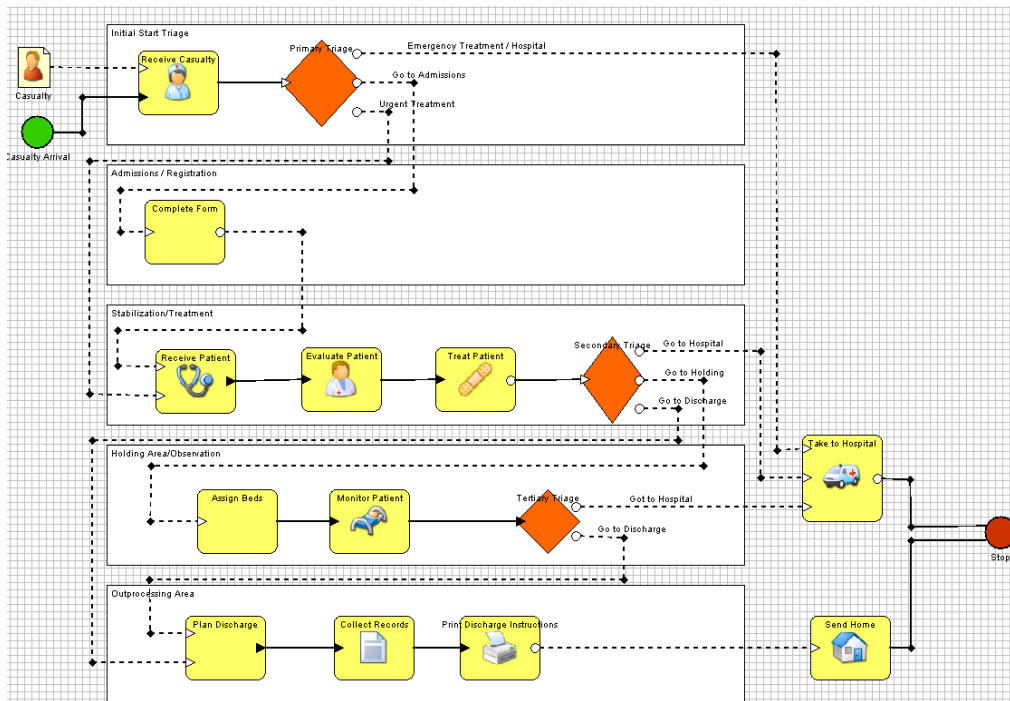

Results: Although general understanding of workflow between processes is well understood, their structure and implementation vary greatly based upon the administrators involved. An initial model of an NEHC was created and refined through interaction with several medical practitioners. The model was simulated and analyzed under various scenarios, and a recommendation was made regarding the resources required at the mass gathering event. However, at the actual mass gathering event, the observed process workflow was quite different. The model was re-created to reflect reality, and the data collected at the mass gathering event were used to verify the results obtained from the new model.

The model was validated for the process workflows implemented, casualty rate experienced, and resource assignments at the mass gathering event. Further, the

primary benefit of having a process model was clearly demonstrated – i.e., the capability of conducting methodical scientific experiments for various scenarios without risk to patients. An ancillary, but important, benefit was that clear documentation of workflow between processes provides all involved with a uniform understanding. The documented model provides a common understanding of workflow, and its simulation can be used as an effective adjunct training tool to assist in the complex management of workflow for emergency medical practitioners.

Simulation Software and Associated Costs

Simulation software can be classified as general-purpose or application-oriented. General-purpose simulation software can be used for any application, with the provision for special constructs for one or more specific applications (such as manufacturing or process engineering). ARENA (Rockwell Automation), ProModel (ProModel Corp.), Simul8 (Simul8 Corp.), ExtendSim (Imagine That, Inc.), @Risk (Palisade Corp.), and Anylogic (XJ Technologies) are examples of general-purpose software. Application-oriented simulation software is designed for specialized domains, such as manufacturing, health care, or airlines. Software such as MedModel Optimization Suite (ProModel Corp.), FlexSim HC (FlexSim Corp.), and Syscape (Edaptive Computing, Inc.) are some examples.²⁴

Compared to the programming language in general-purpose software, application-oriented simulation software has built-in constructs to reduce the modeler's workload. Features such as drag-and-drop, statistical analyses of input data and output information, animation, and report generation are common in such software.

Though the cost of a simulation program may not be prohibitive, the expenditures for personnel and the time required to build a system model can exceed software costs. Depending on the complexity of the system it is intended to capture, a simulation project can take weeks or months to complete. A typical project is two to six months in duration, with costs ranging from \$25,000 to \$75,000.

Future of Simulation in Process Modeling

Our review of the literature suggests that most applications of simulation in healthcare process modeling have focused on modeling a subsystem - e.g., emergency room activity, planning of beds, scheduling of healthcare personnel, patient flow. Investigators conduct subsystem studies to develop insights and to optimize cost-effectiveness. However, optimization for a subsystem does not guarantee an optimal solution for the entire health system. Eldabi et al.² have proposed 'whole system' modeling as a framework for this task. To understand the broader impact of a change in subsystem parameters, a variety of subsystem simulation models can be linked to the whole system conceptual framework. Such a multi-level approach has been used by the military community. The military's comprehensive framework enables simulation to be performed at different levels (e.g., individual missions, fleet engagement, geopolitical events) and includes methods for passing information from one level of simulation to another.

Eldabi et al.² indicate that even though such a multi-layered conceptual framework is available, effective communication between healthcare professionals and simulation experts is mandatory for a successful application. In addition, healthcare professionals need a greater appreciation of the unlimited potential of simulation as a tool for human-in-the-loop support systems that can account for numerous qualitative factors during decision-making. Collaboration between healthcare professionals and simulation experts at facility, regional, and national levels is needed to achieve the benefits inherent in process modeling.

Furthermore, with the increasing use of the Electronic Medical Record (EMR) in healthcare, the applications of simulation will likely grow. Such progress will be driven by the easy availability of the data required to conduct process simulations. The status quo will be advanced when data-driven applications demonstrate the cost-effectiveness of process simulations. The adoption of powerful techniques will become more prevalent, the customer base will grow, and lower software costs will fuel greater activity in process modeling

References

1. Ackermann R, Knip M. Reallocation of beds to reduce waiting time for cardiac surgery. *Health Care Manag Sci* 2007; 7:119-126.
2. Eldabi T, Paul RJ, Young T. Simulation modeling in healthcare: reviewing legacies and investigating futures. *J Oper Res Soc* 2007; 58:262-270.
3. Jacobson SH, Hall SN, Swisher JR. Discrete-event simulation of health care systems. In: Hall RW, ed. Patient flow: reducing delay in healthcare delivery. International Series in Operations Research and Management Science. New York: Springer; 2006
4. Ferreira RB, Coelli FC, Pereira WCA, et al. Optimizing patient flow in a large hospital surgical centre by means of discrete-event computer simulation models. *J Eval Clin Pract* 2008; 14:1031-1037.
5. Troy PM, Rosenberg L. Using simulation to determine the need for ICU beds for surgery patients. *Surgery* 2009; 146:608-620.
6. Marcon E, Kharraja S, Smolski N, et al. Determining the number of beds in the postanesthesia care unit: a computer simulation flow approach. *Anesth Analg* 2003; 96:1415-1423.
7. Masterson BJ, Mihara TG, Miller G, et al. Using models and data to support optimization of the military health system: a case study in an intensive care unit. *Health Care Manag Sci* 2004; 7:217-224.
8. Elkhuizen SG, Das SF, Bakker PJM, et al. Using computer simulation to reduce access time for outpatient departments, *Qual Saf Health Care* 2007; 16:382-386.
9. Van Oostrum JM, Van Houdenhoven M, Vrielink MMJ, et al. A simulation model for determining the optimal size of emergency teams on call in the operating room at night. *Anesth Analg* 2008; 107:1655-1662.
10. Baesler FF, Jahnsen HE, DaCosta M. The use of simulation and design of experiments for estimating maximum capacity in an emergency room. *Proceedings of the 2003 Winter Simulation Conference*; New Orleans, LA, December 2003:1903-1906.
11. Centeno MA, Giachetti R, Linn R, et al. A simulation-ILP based tool for scheduling ER staff. *Proceedings of the 2003 Winter Simulation Conference*; New Orleans, LA, December 2003:1930-1938.

12. Huschka TR, Narr BJ, Denton BT, et al. Using simulation in the implementation of an outpatient procedure center. *Proceedings of the 2008 Winter Simulation Conference*; Miami, FL, December 2008:1547-1552.
13. Kolker A. Process modeling of ICU patient flow: effect of daily load leveling of elective surgeries on ICU diversion. *J Med Syst* 2009; 33:27-40.
14. Johnson WC. Birth of a new maternity process. *Proceedings of the 1998 Winter Simulation Conference*; Washington, DC, December 1998:1429-1432.
15. Ramakrishnan S, Nagarkar K, DeOennaro M, et al. A study of the CT scan area of a healthcare provider. *Proceedings of the 2004 Winter Simulation Conference*; Washington DC, December 2004:2025-2031.
16. Takakuwa S, Wijewickrama A. Optimizing staffing schedule in light of patient satisfaction for the whole outpatient hospital ward. *Proceedings of the 2008 Winter Simulation Conference*; Miami, FL, December 2008:1500-1508.
17. Patvivatsiri L, Fraticelli BMP, Koelling CP. A simulation-based approach for optimal nurse scheduling in an emergency department. *Proceedings of the 2006 Industrial Engineering Research Conference*; Orlando, FL, May 2006.
18. Rohleder TR, Klassen KJ. Rolling horizon appointment scheduling: a simulation study. *Health Care Manag Sci* 2002; 5:201-209.
19. Groothuis S, Van Merode GG, Hasman A. Simulation as decision tool for capacity planning. *Comput Meth Prog Bio* 2001; 66:139-151.
20. Pilgrim H, Tappenden P, Chilcott J, et al. The costs and benefits of bowel cancer service developments using discrete event simulation. *J Oper Res Soc* 2009; 60:1305-1314.
21. Ramwadhoebe S, Buskens E, Sakkers RJB, et al. A tutorial on discrete-event simulation for health policy design and decision making: optimizing pediatric ultrasound screening for hip dysplasia as an illustration. *Health Policy* 2009; 93:143-150.
22. Yurtkuran A, Emel E. Simulation based decision-making for hospital pharmacy management. *Proceedings of the 2008 Winter Simulation Conference*; Miami, FL, December 2008:1539-1546.
23. Katsaliaki K, Brailsford S. Using simulation to improve the blood supply chain. *J Oper Res Soc* 2007; 58:219-227.

24. Institute for Operations Research and Management Science: OR/MS Today.
Available at: <http://www.lionhrtpub.com/orms/surveys/Simulation/Simulation.html>.
Accessed on January 25, 2010

About the Authors

Pratik P arikh, P hD is an Assistant Professor in the Department of Industrial and Human Factors Engineering, College of Engineering and Computer Science, Wright State University. He is interested in applying operations research methodologies to solve real-world problems. Specifically, he employs methodologies such as Mathematical Programming (linear, integer, and mixed-integer), Markov Chains, Order Statistics, Simulation, Meta-Heuristics, and Soft Computing. He has been collaborating with the Department of Surgery at Wright State University Boonshoft School of Medicine and the Dayton VAMC to develop models for allocation of surgical and other health care resources.

Praveen C hawla, PhD is Chief Executive Officer of EDaptive Computing, Inc. EDaptive is a research and development consulting company that provides innovative software products and professional services for rapid analysis and optimization of complex systems and processes. In addition to completing important work in the areas of defense and aerospace, he has developed tools for improving processes in the healthcare arena.

Kashyap Mehta, MS recently completed his Master's degree in the Department of Industrial and Human Factors Engineering, College of Engineering and Computer Science, Wright State University. While earning his degree, he engaged in an independent study project titled Simulation Practice in Healthcare. This project will form part of a Veterans Health Administration curriculum to introduce nonclinicians to the use of simulation-based strategies in healthcare.

Rosalyn P. Scott, MD, MSHA is the Associate Chief of Staff for Medical Education and Director of the Simulation Center at the Dayton VAMC and Professor of Surgery at the Boonshoft School of Medicine, Wright State University. She holds a joint appointment as a Professor of Biomedical, Industrial and Human Factors Engineering

in the College of Engineering and Computer Science at Wright State University. Her simulation-based research interests are in the areas of mixed reality simulations and interactive virtual patients. She is also on the Board of Directors of the MedBiquitous Consortium, an ANSI-accredited developer of information technology standards for healthcare education and competence assessment.

